

**EFFECTS OF VARIOUS FACTORS ON THE SIZING OF
RAIN WATER CISTERN SYSTEMS**

Henry H. Smith

Project No. 375006

Agreement No. 14-08-0001-G-875

September 1983

The research on which this report is based was financed in part by the United States Department of the Interior as authorized by the Water Research and Development Act of 1978 (P.L. 95-467).

Technical Report No. 19
Caribbean Research Institute
College of the Virgin Islands
St. Thomas, U.S.V.I. 00802

DISCLAIMER

Contents of this publication do not necessarily reflect the views and policies of the United States Department of the Interior, nor does mention of trade names or commercial products constitute their endorsement by the U. S. Government.

ABSTRACT

The sizing of rain water cistern systems is properly done by considering several factors. Among these are rainfall frequency, duration and magnitude, demand on the system, characteristics of the catchment area, and the reliability level desired. Models developed in this study consider these factors. Results of simulation varying all of these factors show the changes in volume storage which must be provided. The models demonstrate their usefulness in the proper sizing of cistern systems to satisfy the peculiarities of specific situations.

ACKNOWLEDGEMENT

Assistance in the analysis of data in this study as well as in the development of the models was provided by Mr. Clement Browne, the student research assistant at the Caribbean Research Institute. Mr. Browne's persistence, constancy and willingness to do more than required positively affected the outcome of this study.

TABLE OF CONTENTS

	Page
ABSTRACT -----	iii
ACKNOWLEDGEMENT-----	iv
LIST OF FIGURES -----	vi
LIST OF TABLES -----	vii
INTRODUCTION -----	1
HISTORICAL BACKGROUND -----	2
QUALITY CONSIDERATIONS -----	5
QUANTITY CONSIDERATIONS -----	9
MODEL DEVELOPMENT AND APPLICATION -----	10
CONCLUSIONS AND RECOMMENDATIONS -----	29
REFERENCES -----	30
APPENDIX A - Design Curves for Sprat Hole	
St. Croix, U.S.V.I. -----	AP1
APPENDIX B - Listing of Models Developed -	AP9

LIST OF FIGURES

FIGURE	Page
1. Typical Cistern in the U. S. Virgin Islands -----	4
2. Computation of Minimum Feasible Required Storage--	16
3. Flowchart of CISTERN RELIABILITY -----	17
4. 21-Year Weekly Rainfall Averages at Sprat Hole, St. Croix, U.S.V.I. -----	20
5. Design Curves for Sprat Hole, St. Croix for Several Demand Levels with 85% Catchment Efficiency -----	21
6. Average Monthly Rainfall in Tortola, B.V.I and Anguilla, B.W.I -----	23
7. Average Monthly Rainfall at George Town, Grand Cayman, British West Indies and Koror, Belau -----	24
8. Design Curves for Anguilla, B.W.I. with 85% Catchment Efficiency for Several Demands-----	25
9. Design Curves for Grand Cayman, B.W.I with 85% Catchment Efficiency for Several Demands -----	26
10. Design Curves for Koror, Belau, with 85% Catch- ment Efficiency for Several Demands -----	27
11. Design Curves for Tortola B.V.I with 85% Catchment Efficiency for Several Demands -----	28

LIST OF TABLES

TABLE	Page
1. Relative Efficiencies of Various Foul Flush Devices -----	7
2. Catchment Efficiencies Used in the Literature -----	11

INTRODUCTION

Rain water cistern systems are a widely used but not very heralded supply of water throughout the world. These systems have for centuries been the only source of water in some areas and are once again being turned to as a supplemental source where water demands have increased and where modern technology, largely on account of the associated expense, has failed.

While the original intentions of this study were abridged because of tightened time constraints, the investigations described would be useful in the development of guidelines for the utilization of cistern systems either individually or in conjunction with supplemental sources of water for domestic use.

A short historical overview of rain water cistern useage is made followed by an examination of a few of the quality aspects which must be considered with rain water cistern systems. An in depth investigation then is made of several factors affecting the sizing of these systems. These factors are the expected demand on the systems, the required reliability, the rainfall amount and distribution and the catchment efficiency.

HISTORICAL BACKGROUND

While no one can document the earliest cisterns, their usage have been recorded as far back as 2000 B.C. in the Middle East where typical middle class dwellings stored rain water in cisterns. Throughout history, the use of these systems have continued. In the eighth century the Greeks constructed houses with cisterns and Hippocrates advocated boiling water for disinfection as did the Egyptians in Alexandria where prominent families utilized cisterns.

In ancient Turkey, cisterns were included in the water works for as far back as the second millenium B.C. during the Hittite Period. Cisterns were the principal source of water in elevated locations in Anatolia and several other cities, and were constructed to serve as emergency sources in case of warfare. In the Yucatan peninsula, recent discoveries have shown that cisterns were in use during what is refered to as the Maya Period, beginning about 300A.D. Cisterns later played a vital part in the development of Mayan culture and in the lives of the present inhabitants of the Yucatan peninsula.¹

In the eastern United States, during the early settlement of the country, rain was collected from rooftops and used in households. In the early part of the 19th century a law was passed in New York to construct public cisterns to collect rain from public buildings for use in fire protection.

In Hawaii, rainfall catchment has long been a source of domestic and livestock water supply. The earliest report on rain catchment in

Hawaii (1915) estimated an average catchment area of 100 square feet per person with an average tank capacity of 1000 gallons per person and an average water use rate of 10 gallons per person per day.²

Throughout the Caribbean, cisterns are often the principal source of water and in some areas are required by law. In the Cayman Islands cisterns provide 68% of the household water.³ In the United States Virgin Islands and the British Virgin Islands all residential buildings must provide at least ten gallons of cistern storage for each square of roof area. In Bermuda, a minimum of ten gallons of cistern storage must be provided for at least 80% of the roof area. In Bermuda cisterns provide approximately 1.6 million gallons of water per day and in the U.S. Virgin Islands they serve as the principal source of water for over 75% of the residents.

Cisterns in the Virgin Islands generally form an integral part of residential structures. Though often many innovative and imaginative approaches have been used in the design of these cisterns in incorporating them into buildings, the practice generally is to have them form a part of the foundation. Typically they appear and are constructed as shown in Figure 1.

ICWRM CURRENT STATUS

STUDENT ENROLLMENT

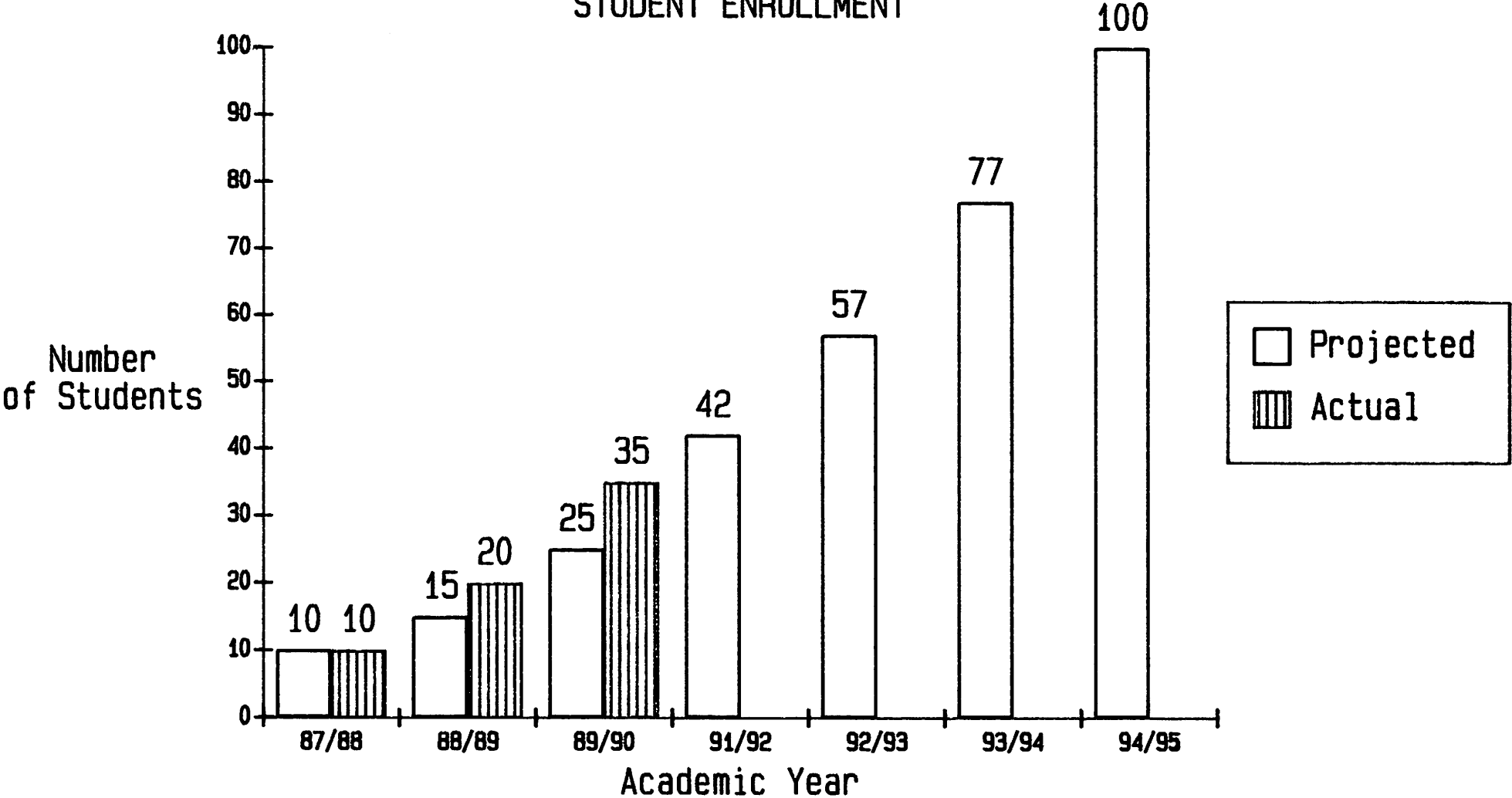

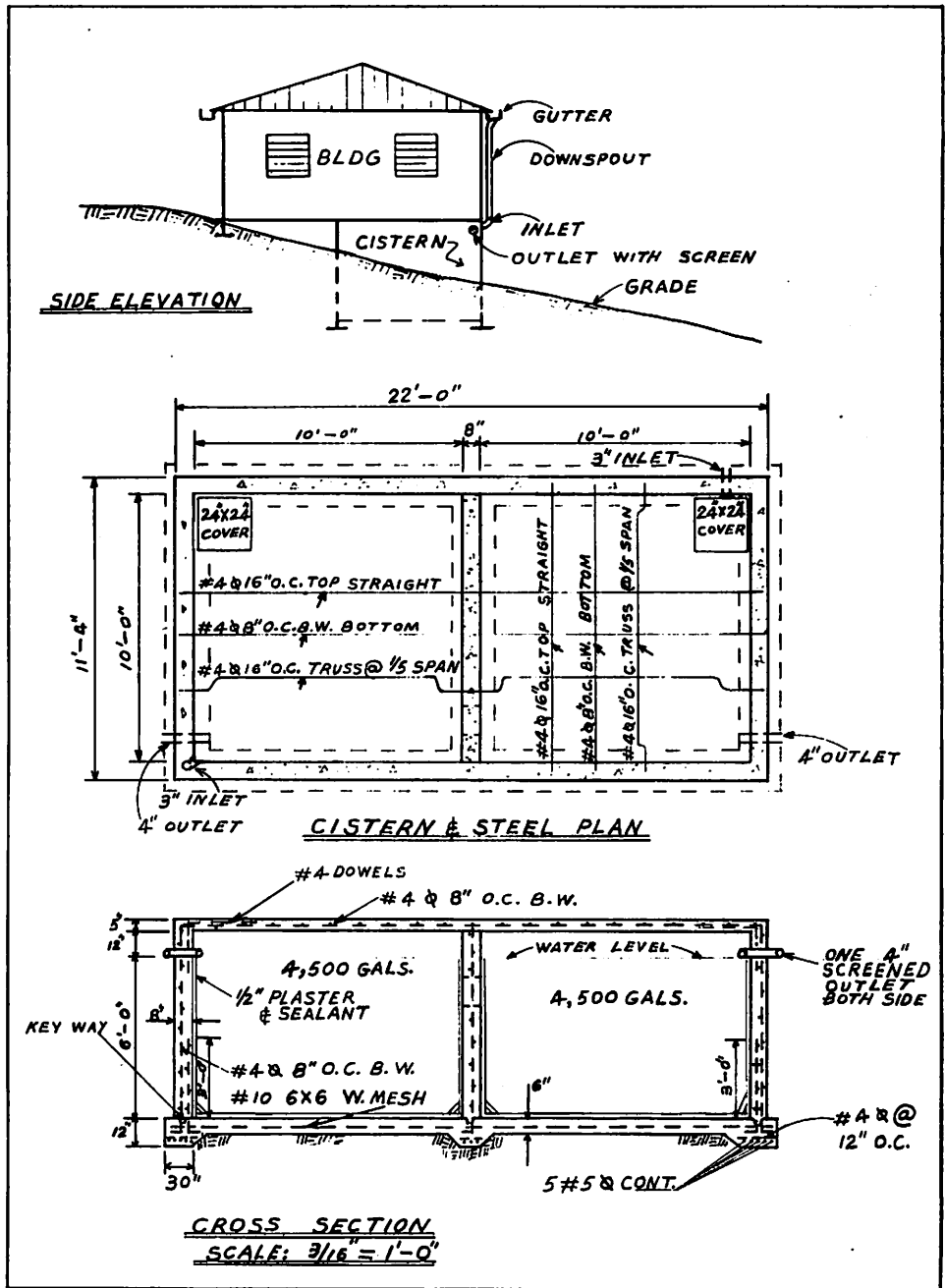

Figure 1

Typical Cistern in the U. S. Virgin Islands
(Not to scale indicated)

QUALITY CONSIDERATIONS

Collected rain water may be contaminated from a myriad of sources.

As expressed by Rinehart:

Cistern water contains atmospheric dust and aerosols, accumulated dust and debris from roofs, breakdown products from roofing materials, organic debris from overhanging trees, micro-organisms, fecal material from rodents, birds and lizards, and salt deposited from sea spray. During storage, it interacts with cistern walls. Frogs may visit or reside in the cistern. Under special circumstances,⁴ the cistern itself can be subjected to ground water seepage.

While no recent study has been made of rainfall quality in the Virgin Islands, the potential for acid rain and dry deposition as described by Hicks does exist.⁵ Pesticide contamination of Virgin Islands cistern water has been documented in a report by Lenon, Curry, Miller and Patulski.⁶

Of greater importance than the quality of the rain, is the quality of the water when it is to be put to use. This quality may be influenced by the characteristics of the roofing material used, such as its roughness and likelihood of retaining pollutants, the paint or other agent used to coat the roof, its slope, the proximity of trees, birds and other sources of deposits on the roof.

To enhance the quality of the harvested water before it enters the cistern, various strategies for diversion of the initial five to ten minutes of highly polluted foul flush are practiced. Jenkins and

Pearson ⁷ have presented a very good analysis of this foul flush. These strategies are said to for a small investment yeild a marked improvement in the quality of water in storage and are often recommended over filters which tend to clog and become contaminated resulting in relatively high maintenance requirements. Table 1 based on information from Michaelides and Young⁸ indicates the relative efficiencies of ten foul flush separation devices in preventing soluble and particulate pollutants from entering storage.

Jenkins and Pearson⁹ and Young and Sharpe¹⁰ has detailed elaborate and very effective procedures to treat cistern water. Canoy and Knudsen¹¹ recommend a far simpler procedure:

Every household with a cistern water supply should practice chlorination for their cistern storage water; sufficiently strong solutions of chlorine such as 'Clorox', should be added to the cistern each night so that the residual total chlorine the next morning is on the order of 0.5 mg Cl /L or greater, based on measurements with a DPD chlorine colorimetric test kit. New cistern water supply systems should be required to be constructed to filter debris and to facilitate the addition of chlorine to the storage tanks. One way to accomplish this would be to provide plastic piping which would allow the addition of chlorine from the main part of the house, and which would preferably distribute the chlorine to several locations within the tank. A water depth indicator in the cistern supply tank would also be desirable to aid in determining how much chlorine is needed. It is realized that the addition of chlorine in this manner will increase the chlorinated organics content of the cistern water supply. However, in the opinion of the authors, the health risk of the increased concentrations is small when compared to the risk¹¹ of promoting entric disease if the chlorine were not added.

It is interesting to note that a study by Coffin and Richardson¹² for the Virgin Islands Water Resources Research Center revealed that from a survey conducted, 68.4 percent of the respondents used cistern water as their principal source of drinking water and 65 percent of

TABLE 1
RELATIVE EFFICIENCIES OF VARIOUS FOUL FLUSH DEVICES

	Movable Downpipe	Movable Tank	Removable Tank Covers	Diversion Valve	Simple Foul Flush Box with Drain Tap	Simple Foul Flush Box with Trickle Drain	Baffle Modification of Simple Foul Flush Box	Foul Flush Box with Floating Ball	Tipping Twin Funnel	Pivoting Trough
Operation	Manual	Manual	Manual	Manual	Semi-Automatic	Automatic	Semi-Automatic or Automatic	Semi-Automatic or Automatic	Automatic	Automatic
Enables Rejection of an Initial Flush of Soluble Pollutants	XX	XX	XX	XX	00	00	00	XX	XX	XX
Reduces Undesirable Flows of Suspended Particles	XX	XX	XX	XX	To Some Extent if Maintained		XX	XX	XX	XX

these respondents felt that they would choose cistern water over all other sources if they had no constraints. 51 percent of the respondents said that they choose not to boil their drinking water.

QUANTITY CONSIDERATIONS

The five major design factors for cistern systems are:

- i. The amount and distribution of rainfall available for use.
- ii. The amount and characteristics of the catchment area.
- iii. The water demand.
- iv. The storage capacity.
- v. Economics.

Large cisterns are costly. The cost of materials for construction of the cistern illustrated in Figure 1 is approximately \$5000.00. However in many areas cisterns may be the most reliable or the only source of water. In such areas, water is very dear and is used accordingly.

The designer of the cistern has no control on the demand that will be exerted on the cistern system by the user. Nor does the designer control the amount and distribution of rainfall or to a significant extent the size of the catchment area. What the designer must concentrate on is the optimum storage capacity when the other factors are considered. Schiller and Latham¹³ reviewed several methods which were modifications of the popular Rippl mass curve method. The methods they reviewed included the mass curve based on hydrologic data, the yield after storage (YAS) method, the rationing and stocking model and Ree's statistical method. In addition to these methods, several others were presented at the First and Second International Conferences on Rain Water Cistern Systems and are detailed in the proceedings for these conferences. 14, 15

MODEL DEVELOPMENT AND APPLICATION

In the present study, two simulation models were developed to examine the effects of various parameters on the cistern capacity. While several approaches to this problem have been taken in reservoir sizing studies, because of limitations of the computer facilities available for this study, model development was forced to consider computer storage limitations. Particularly beneficial in developing a model with these constraints is that the end result will be a product that is usable to others with similar constraints. The model presented was developed using an Apple II micro-computer.

A first approach to the model then would consider for each time period the rainfall input (RA), the volume of water harvested (HA) which is function of the amount of rainfall, the catchment area (CA) and the catchment efficiency (CE).

$$HA = RA (CA \times CE) \quad (1)$$

Catchment efficiency is a term that accounts for several factors which may affect the eventual discharge of the rain that comes in contact with the roof surface. Among these are the catchment slope, the degree of imperviousness, and the roughness. Various coefficients have been used throughout the literature to serve the same role that the catchment efficiency factor does here. Several of these are listed in Table 2.

From the harvested rainfall of Equation (1), the weekly demand (DM) is subtracted. This procedure of subtracting the demand from the harvested amount is similar to the Jenkins and Pearson's yield before

TABLE 2

Catchment Efficiencies Used in
the Literature

Catchment Efficiency	Source
0.70	Waller and Inman, 1982 ¹⁶
0.70	Piggot, et al, 1982 ¹⁷
0.90	Pompe, 1982 ¹⁸
0.75	Waller, 1982 ¹⁹
0.90	Rakocy, 1984 ²⁰
0.75-0.80	Buros, 1976 ²¹

storage (YBS) model.²² Alternatively the harvested rain could have been added to the amount in storage where spillage would occur if necessary and then the demand satisfied. This approach is analogous to Jenkins and Pearson's yield after storage (YAS) model.²³ In the model being developed demand is first satisfied from the harvested rain, the excess rain added to storage and then spillage, if any, takes place. If the harvested rain does not satisfy the demand, the excess demand is added to storage. Jenkins and Pearson²⁴ also proposed a yield and rainfall distributed (YRD) model for use in estimating day by day system performance. For the week by week simulation in the model being developed, the approach similar to the YBS model seemed more suitable.

At each time step the volume of water remaining in storage is determined as well as whether or not the demand was satisfied. The cycle is repeated for each week throughout the simulation period.

The reliability of the system is defined to be the fraction of the simulation period that the system will meet demands. Each time the system "fails" (does not meet demand) a deficit (DE) occurs. Reliability (DR) is calculated as:

$$DR < 1 - [DE / (NY * 52)] \quad (2)$$

DR = desired reliability

DE = cumulative occurrences of deficits in the simulation period

NY = number of years of record

storage (YBS) model.²² Alternatively the harvested rain could have been added to the amount in storage where spillage would occur if necessary and then the demand satisfied. This approach is analogous to Jenkins and Pearson's yield after storage (YAS) model.²³ In the model being developed demand is first satisfied from the harvested rain, the excess rain added to storage and then spillage, if any, takes place. If the harvested rain does not satisfy the demand, the excess demand is added to storage. Jenkins and Pearson²⁴ also proposed a yield and rainfall distributed (YRD) model for use in estimating day by day system performance. For the week by week simulation in the model being developed, the approach similar to the YBS model seemed more suitable.

At each time step the volume of water remaining in storage is determined as well as whether or not the demand was satisfied. The cycle is repeated for each week throughout the simulation period.

The reliability of the system is defined to be the fraction of the simulation period that the system will meet demands. Each time the system "fails" (does not meet demand) a deficit (DE) occurs. Reliability (DR) is calculated as:

$$DR < 1 - [DE / (NY * 52)] \quad (2)$$

DR = desired reliability

DE = cumulative occurrences of deficits in the simulation period

NY = number of years of record

At the end of the specified simulation period, the reliability of a system with a specified roof area, demand rate and cistern capacity is determined.

Since it may be desirable to determine the effectiveness of various storage capacities, a procedure was incorporated into the model that permits a user to specify a reliability and demand and the model will determine the corresponding storage, if possible, that would meet these requirements.

Additionally, at times it may be desirable to determine for a specified demand the storage that would be required to meet several reliabilities. Alternatively, for a specified reliability, the storage which must be provided to meet various demands may be desired. The first case was addressed in a variation of the original model called CISTERN DEMAND and the second case in a similar variation called CISTERN RELIABILITY.

As work progressed with the models it was determined that modifications could be made to reduce computational time and steps. The first of these modifications would halt execution in the simulation period as soon as the minimum desired reliability was not met. This procedure is best illustrated by using an extreme case as an example. Assume that the unrealistic reliability of 100% is specified for a 10 year simulation period. If in the second week of the third year the system fails then there is no need for the simulation to proceed further. In this example, DR in Equation (1) is 1, and NY is 10. When the system fails for the first time, DE becomes 1 and Equation (2) cannot be satisfied. With other specified reliabilities DE may increase until Equation (2) can no longer be satisfied.

The model then increments the specified minimum storage and the simulation begins again and continues either to the end of the simulation period or until the desired reliability cannot be met. The incremental increase in minimum storage (gallons/square foot of roof area) was used as 0.5. This may be changed as the model user prefers. A maximum limit of 30 gallons storage/per square foot of roof area has been placed in the model to prevent unrealistic determinations.

Storage is not always the limiting factor in rain water cistern systems. While impressive volumes of storage may be provided, unless the rainfall and demand are such that the storage is at times all used, then a wasteful excess of storage has been provided. In the simulation model, if for the simulation period a specified reliability has not been met, unless during the period some spillage has occurred then it is useless to provide additional storage and go through the simulation again. In the model each time the storage volume is exceeded and a spill occurs, a variable called "SPILL" is set to a non-zero value. At the point in the simulation where it is determined that the desired reliability cannot be met, a check is made to see if SPILL is non-zero. If it is, then the storage is increased and the simulation repeated. If it is zero, then the desired reliability cannot be met for provision of additional storage will not result in any water savings.

Previously, it was explained that if in determining the minimum required storage to meet some capacity, it became apparent that the required storage would be greater than or equal to 30 gallons per square foot of catchment area, the computations would cease. Provisions were also made in the model to discontinue calculations when the difference between required storage for two consecutive reliabilities (or demands)

exceed five gallons per square foot of catchment area. This provision was also made to curtail unrealistic determinations of cistern capacity.

In the model, when the minimum required storage for a series of increasing reliabilities is being determined, it is obvious that for a reliability level above the next lower level, the required storage is at a minimum the required storage of the lower level. More significantly, there will be a minimum increase in storage between incremental reliability levels equal to at least the differences in storages corresponding to the previous two consecutive reliability levels. To illustrate this, (Figure 2), let S_1 and S_2 be the minimum required storage which must be provided to obtain respective reliabilities of R_1 and R_2 . Let S_{2-1} be the difference between S_2 and S_1 . S_3 then is a minimum of $S_2 + S_{2-1}$.

A flowchart of the complete CISTERN RELIABILITY model appears in Figure 3. Listings for CISTERN RELIABILITY and CISTERN DEMAND are to be found in Appendix B.

The model was used with 21 years of weekly rainfall data from Sprat Hole, St. Croix, U. S. Virgin Islands. The weekly averages of this data are as shown in Figure 4. For catchment efficiencies ranging from 0.70 to 1.00, the cistern storage capacity necessary to provide water over the historical period for demands ranging from 500 gallons to 1200 gallons per week were determined. Reliability of these systems ranged from 50 percent to 95 percent. The catchment area remained constant at 1600 square feet. The results obtained for a catchment efficiency of 85% are presented in Figure 5 and for the other catchment efficiency levels in Appendix A.

CISTERN SAND FILTERS

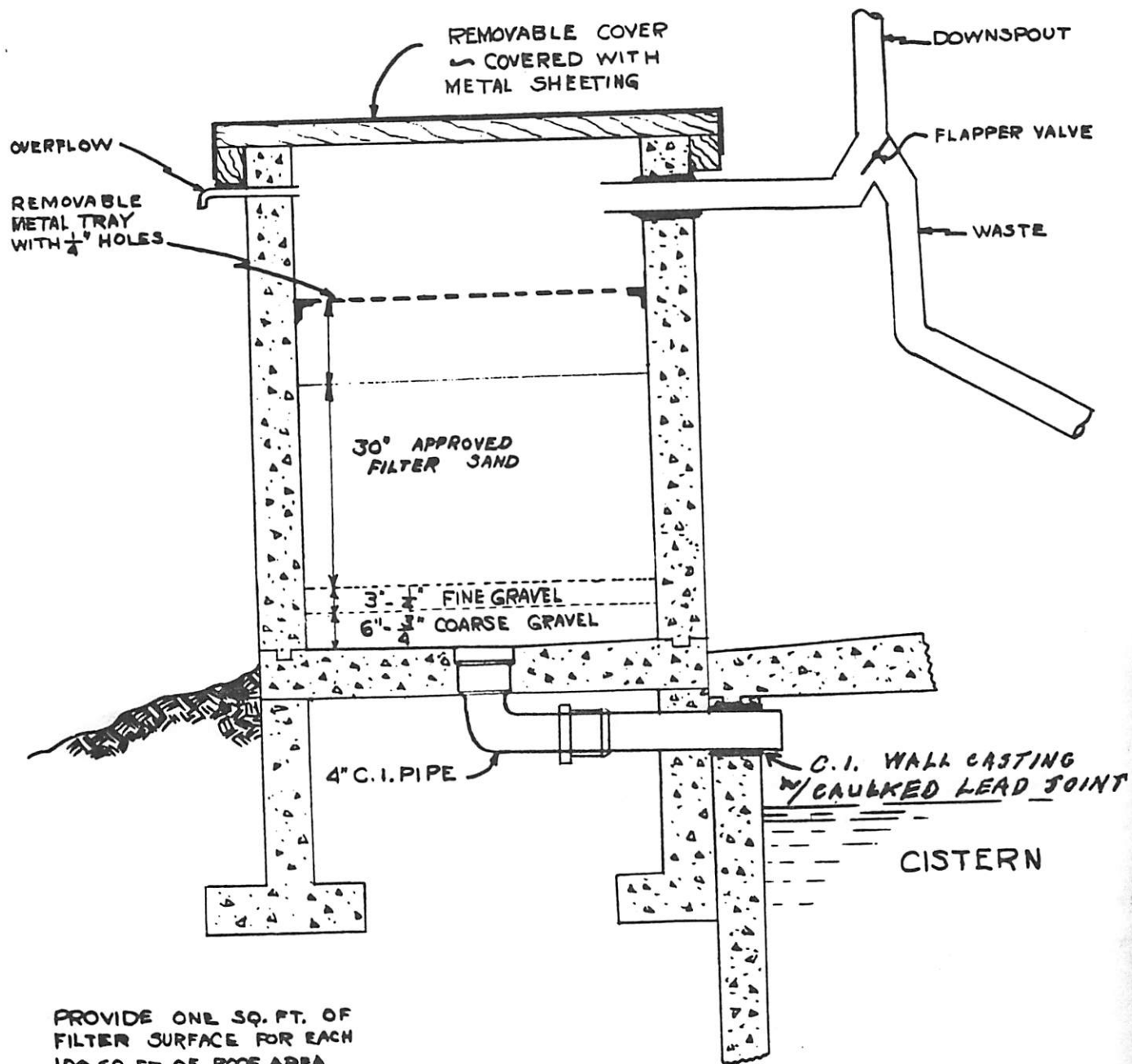

PROVIDE ONE SQ. FT. OF FILTER SURFACE FOR EACH 100 SQ. FT. OF ROOF AREA.

SAND FILTER
MAY BE USED IN PLACE OF ROOF WASHER WITH APPROVED CISTERN

NOT TO SCALE

Figure 44.

DISTRIBUTION OF TYPES OF DEVELOPMENTS GALLIA COUNTY

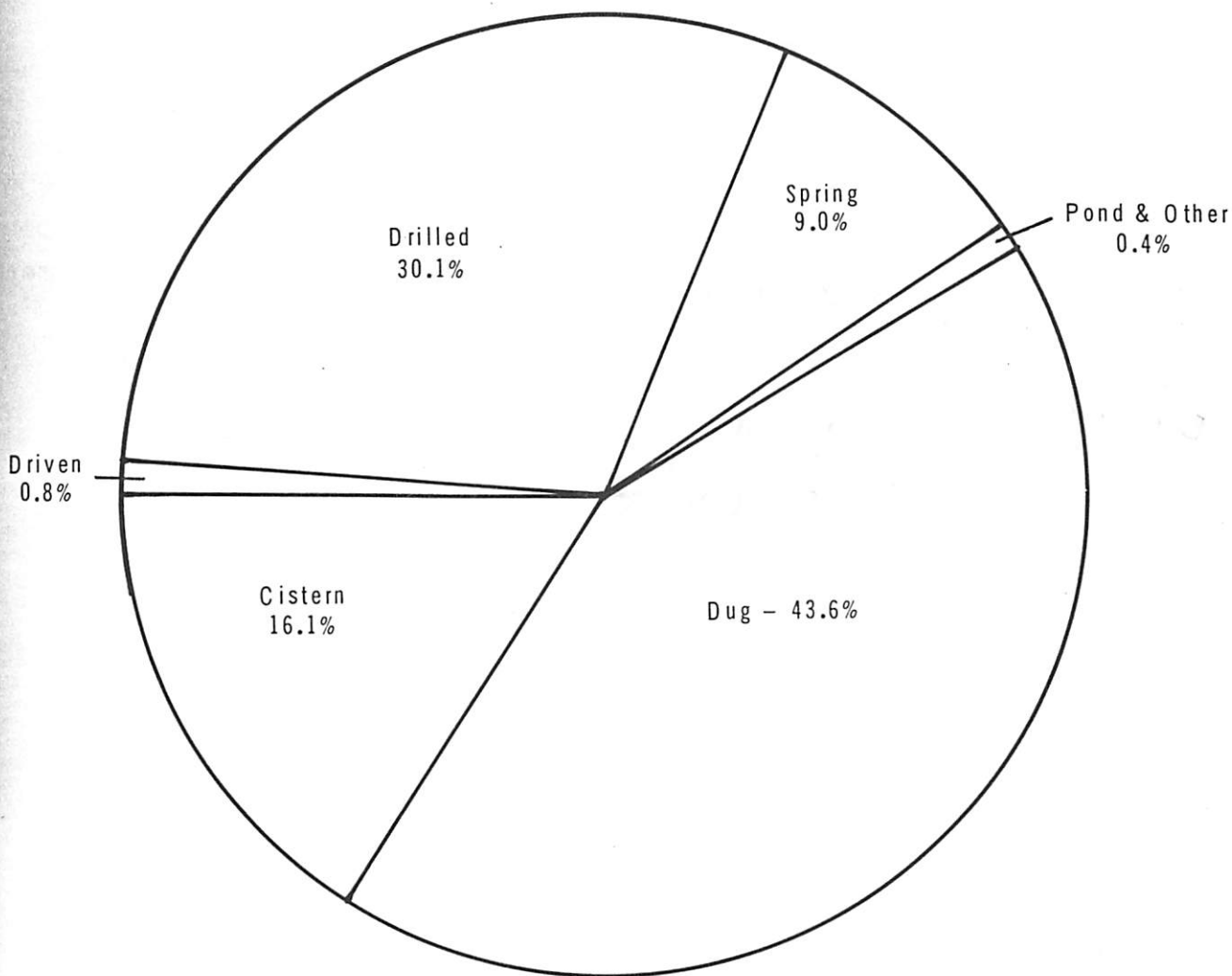

Table XIX.

COMPARISON OF DEVELOPMENTS BY % SAFE

		% Safe	# of Systems Sampled
Drilled	—	75.5	294
Driven	—	50.0	8
Pond & Other	—	50.0	4
Dug	—	32.9	425
Cistern	—	32.5	157
Spring	—	28.4	88

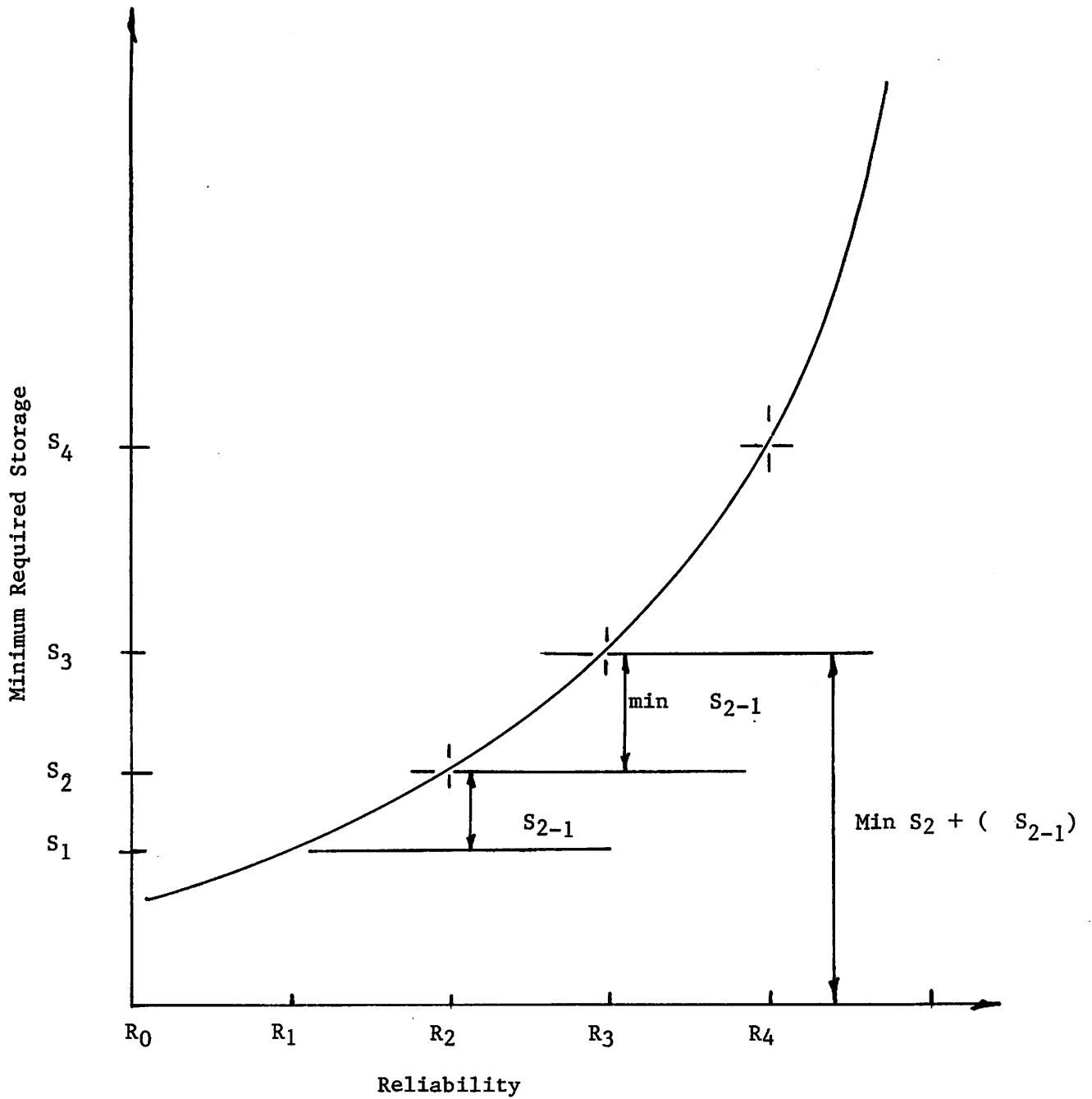

Figure 2

Computation of Minimum Feasible Required Storage

FLOWCHART OF CISTERN RELIABILITY

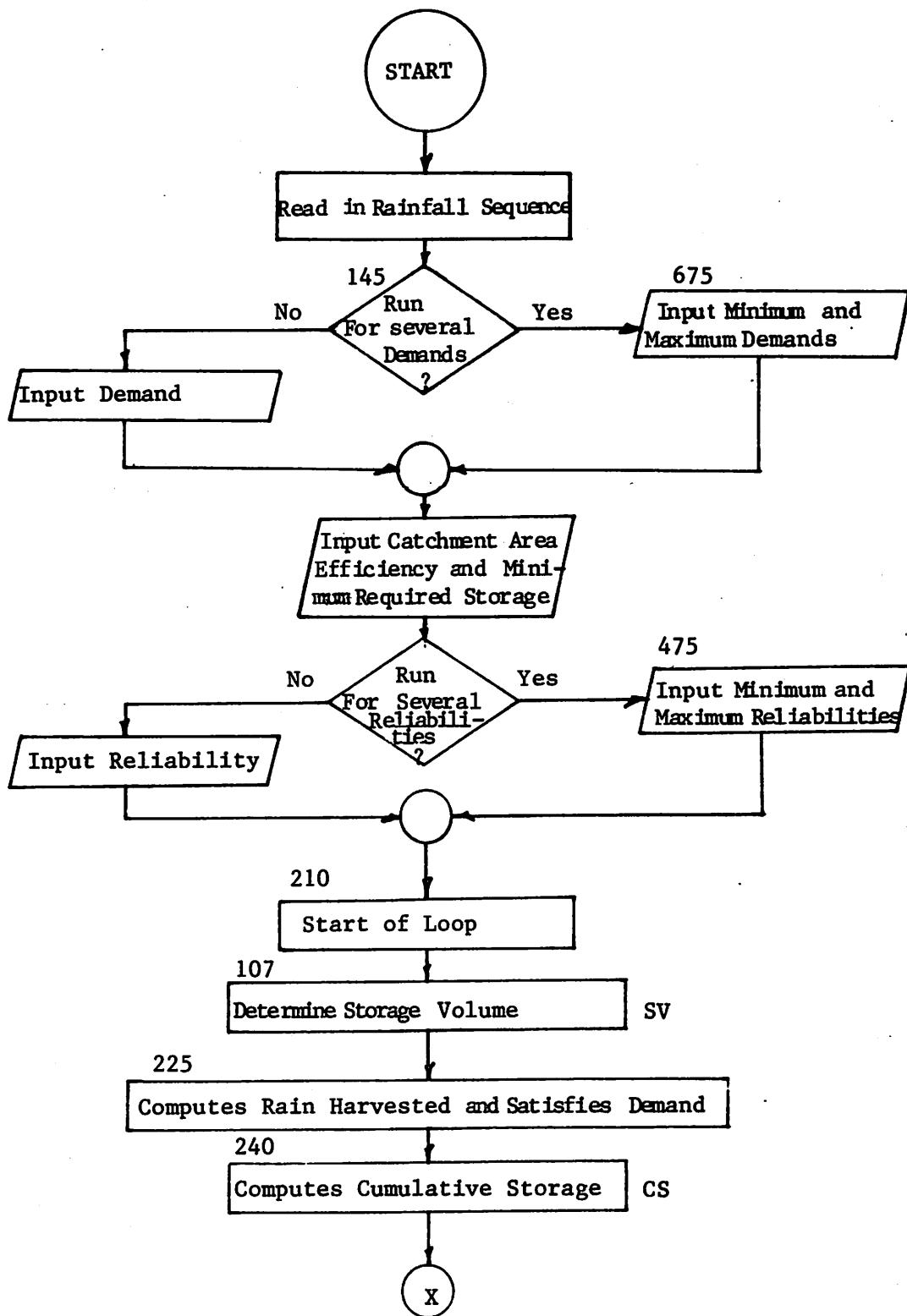
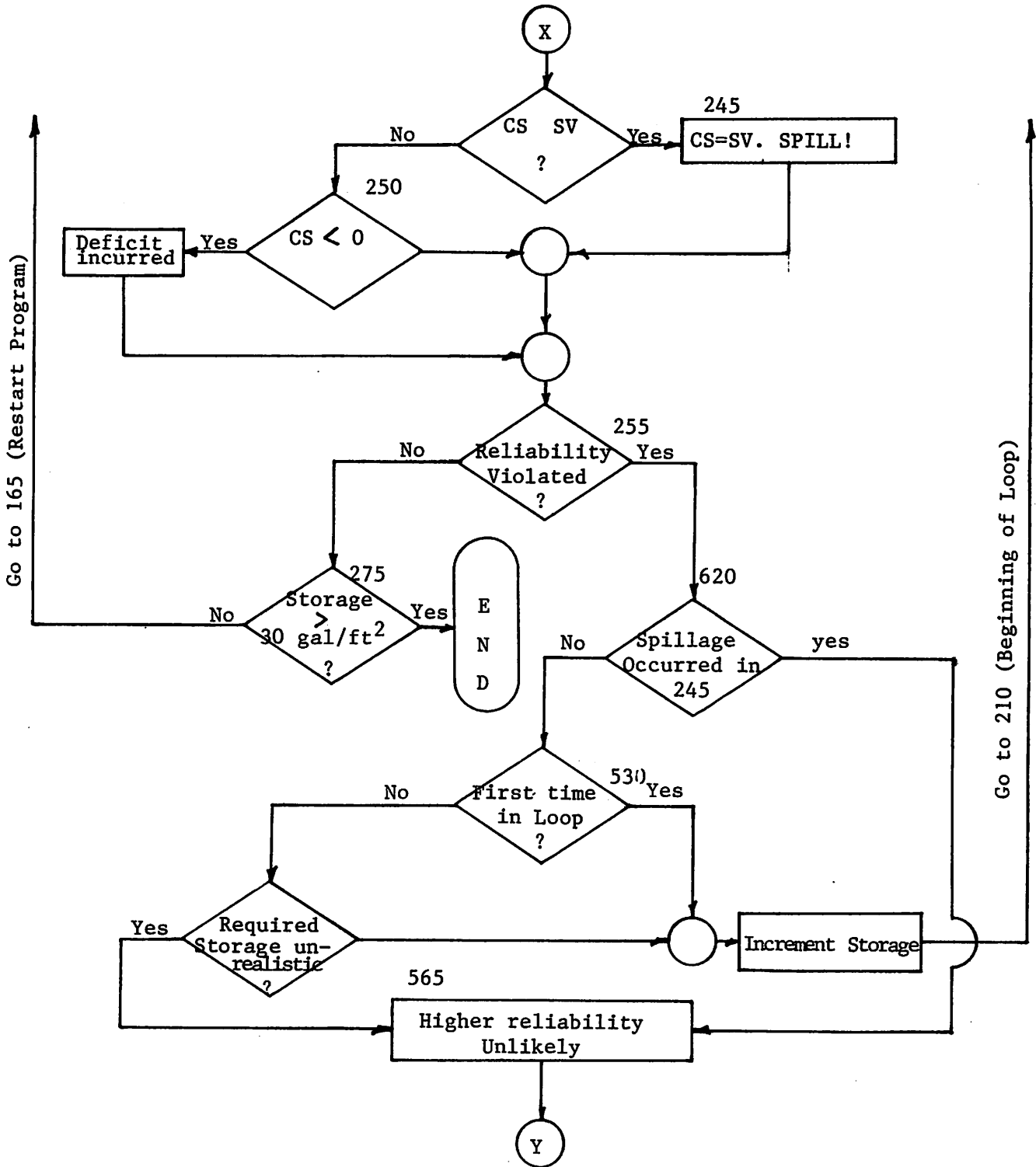
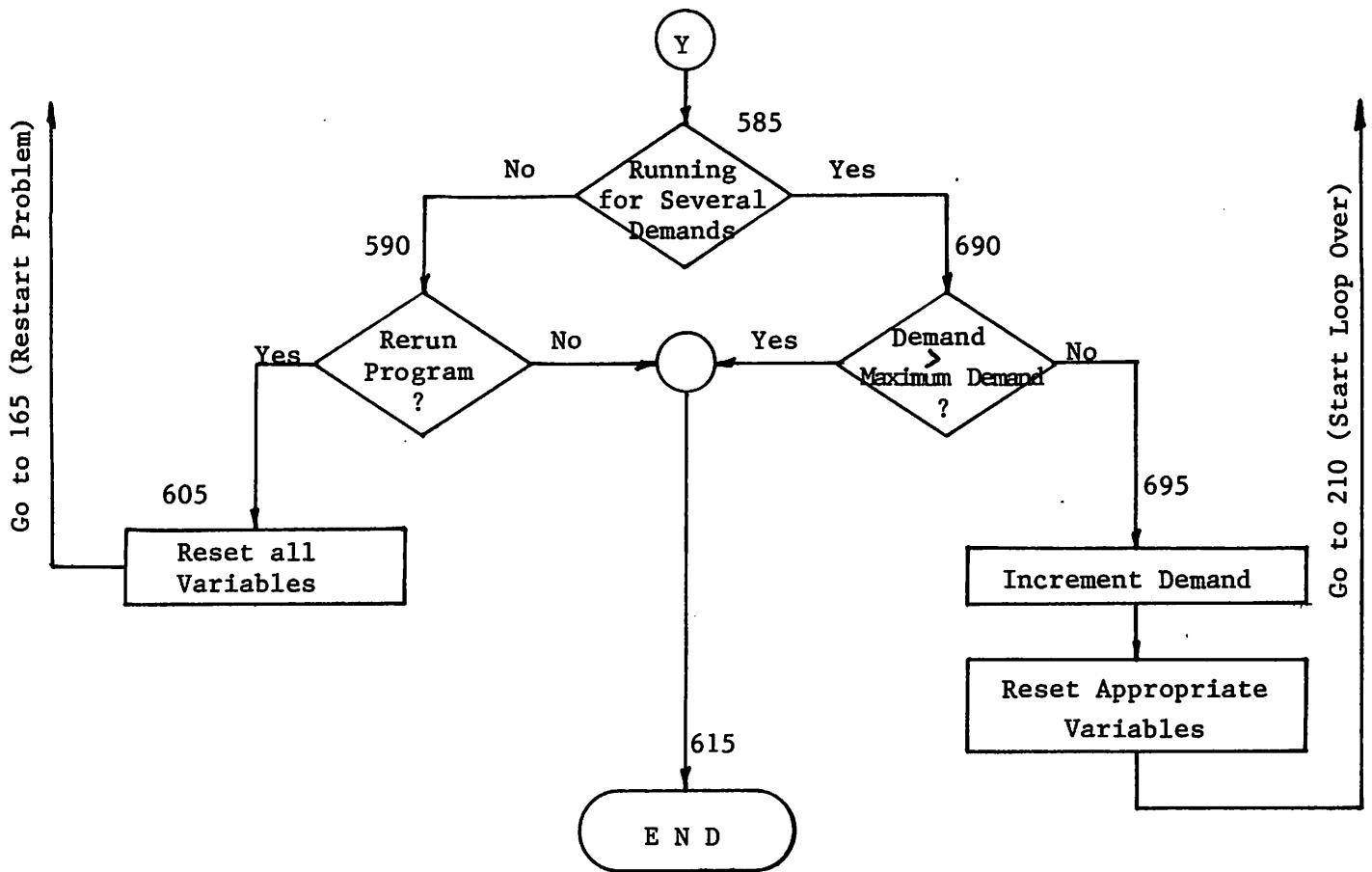

Figure 3

(Flowchart of CISTERN RELIABILITY Cont'd)





Note: Numbers on flowchart refer to statement numbers in the program.

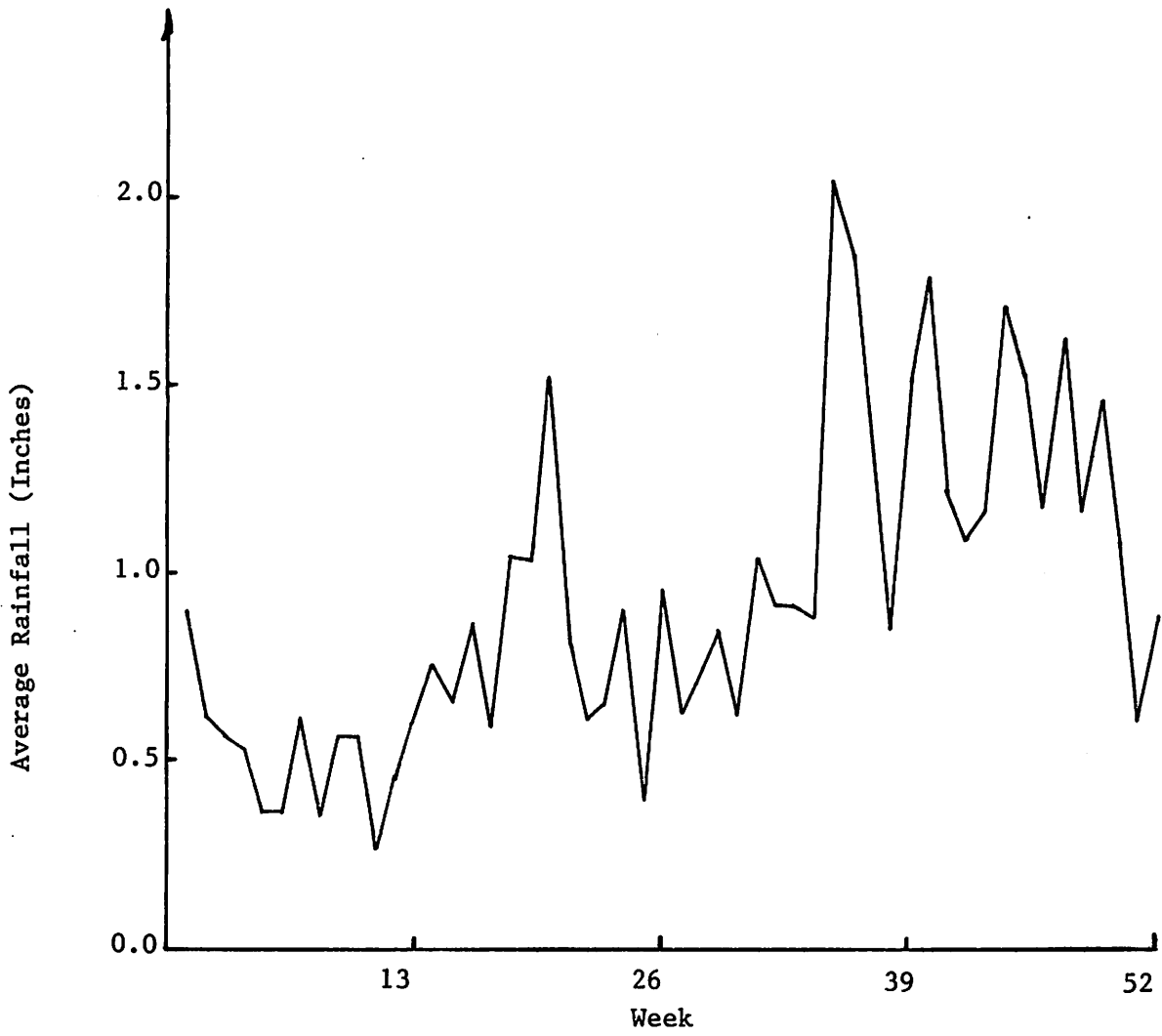

Figure 4

21-Year Weekly Rainfall Averages at Sprat Hole, St. Croix, U.S.V.I

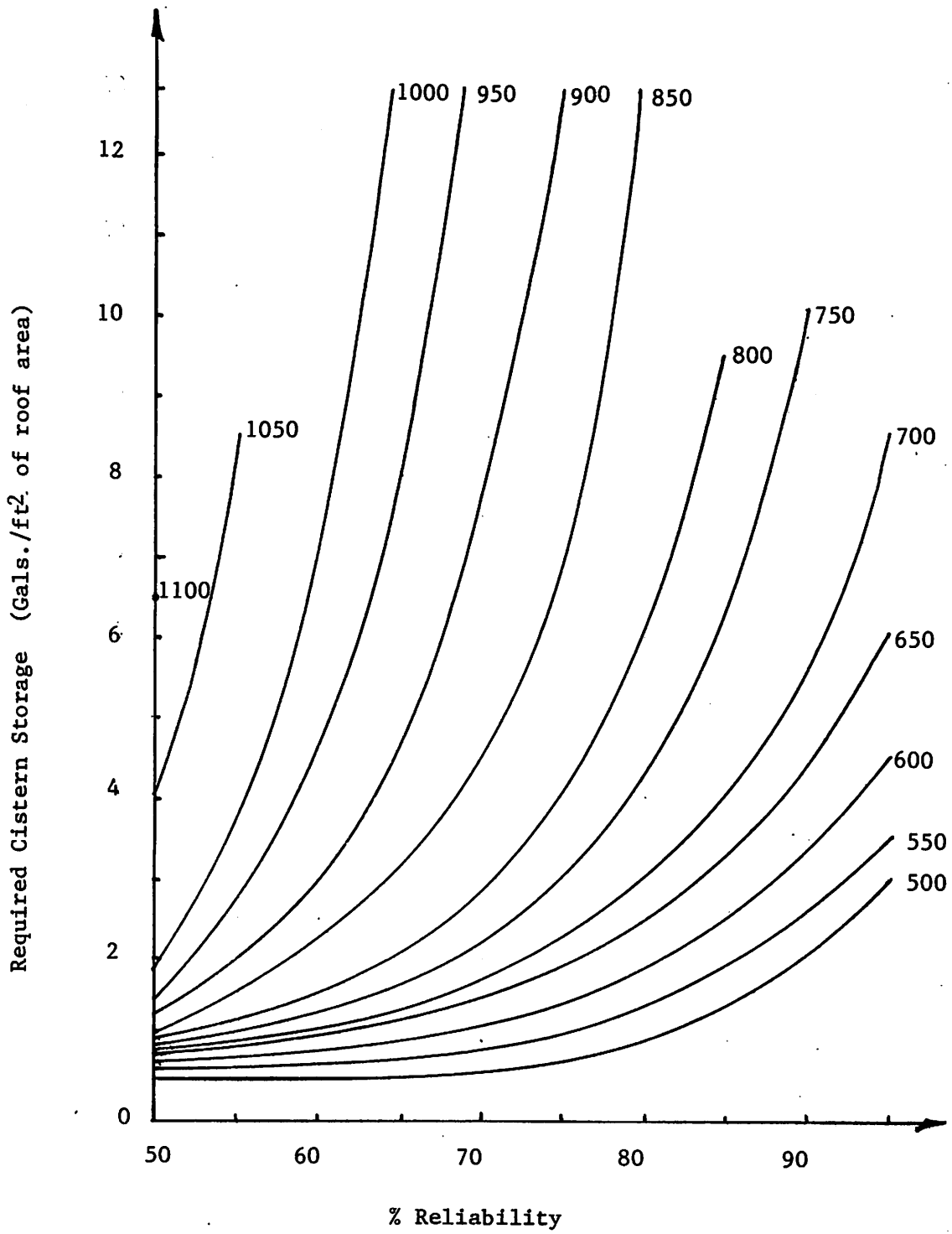

Figure 5

Design Curves for Sprat Hole, St. Croix for Several Demand Levels with 85% Catchment Efficiency

To illustrate the effects that rainfall quantity and distribution might have on desirable storage volumes, the models were applied to monthly rainfall data from Tortola, British Virgin Islands,²⁶ Anguilla, British West Indies,²⁷ and Grand Cayman, British West Indies,²⁸ all in the Atlantic Ocean. Also the models were applied to monthly rain data from Koror, Belau²⁹ in the Pacific Ocean. Average monthly rainfall for these sites are plotted in Figures 6 and 7. In these simulations a catchment area of 1600 square feet with a catchment efficiency of 85%. Several monthly demand levels were used. Results are presented in Figures 8,9,10 and 11.

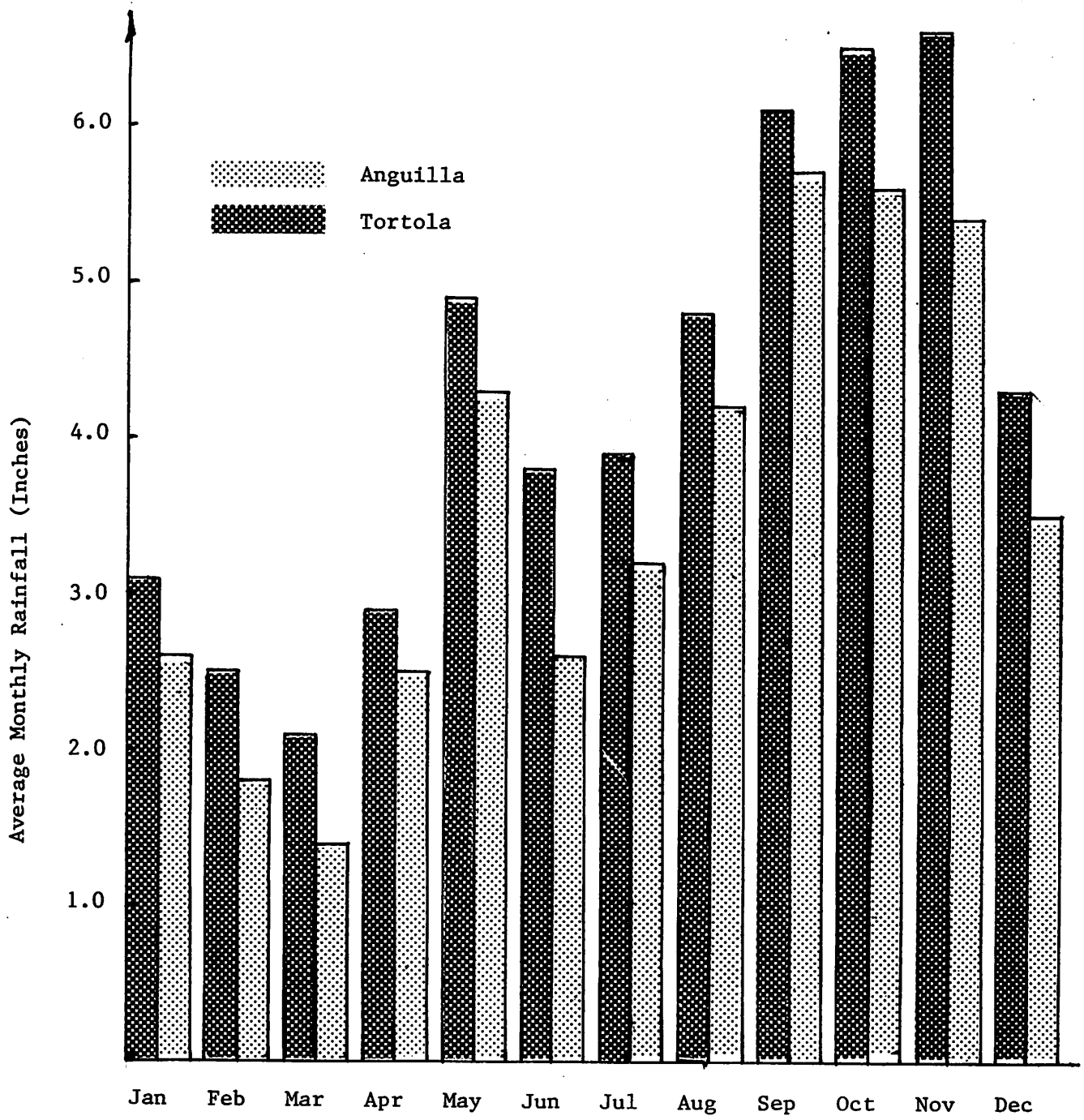

Figure 6

Average Monthly Rainfall in Tortola, B.V.I. and Anguilla, B.W.I.

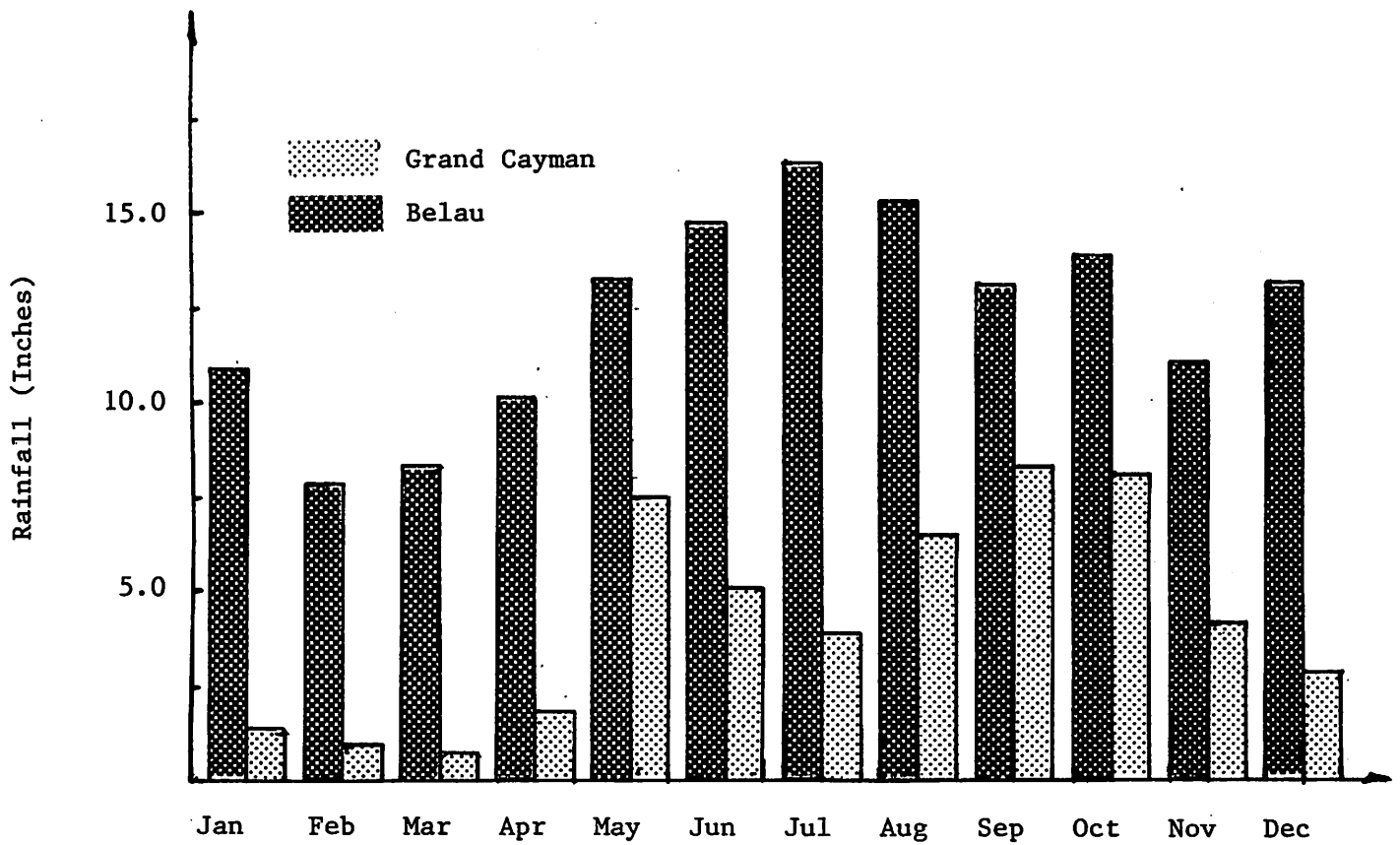

Figure 7

Average Monthly Rainfall at George Town, Grand Cayman,
British West Indies and at Koror, Belau

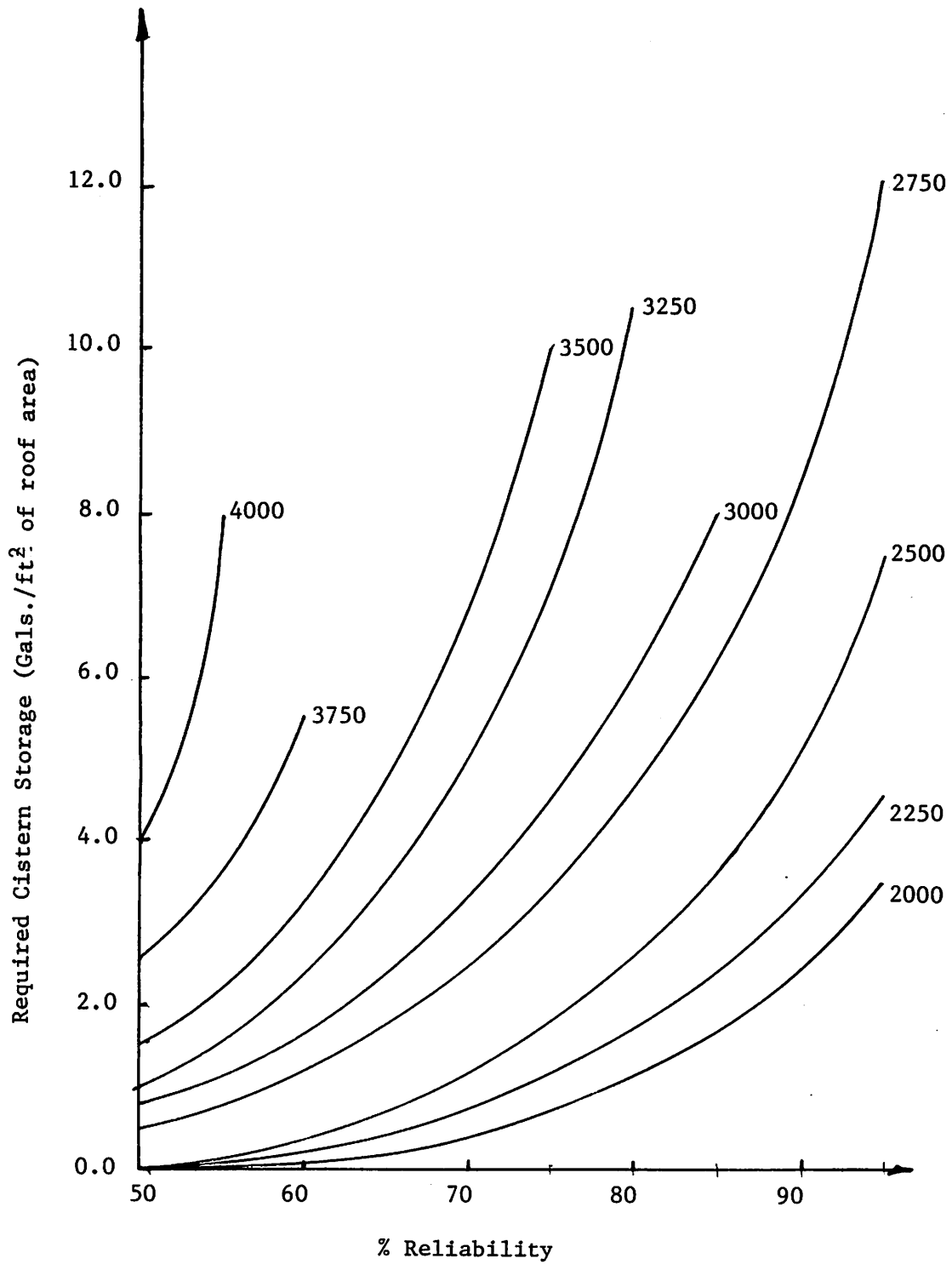

Figure 8

Design Curves for Anguilla, BWI with 85% Catchment Efficiency
For Several Demands

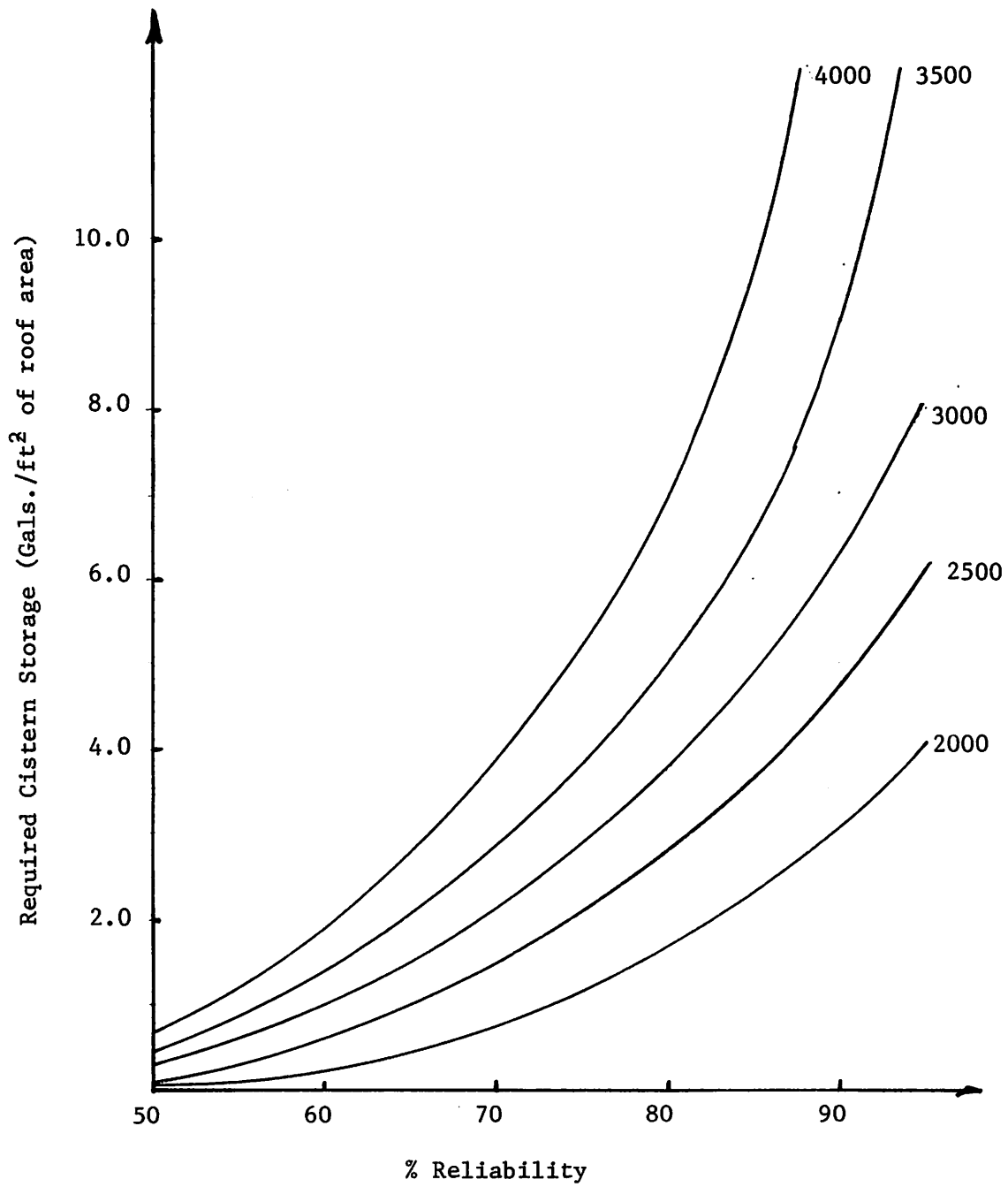

Figure 9

Design Curves for Grand Cayman, BWI with 85% Catchment Efficiency
For Several Demands

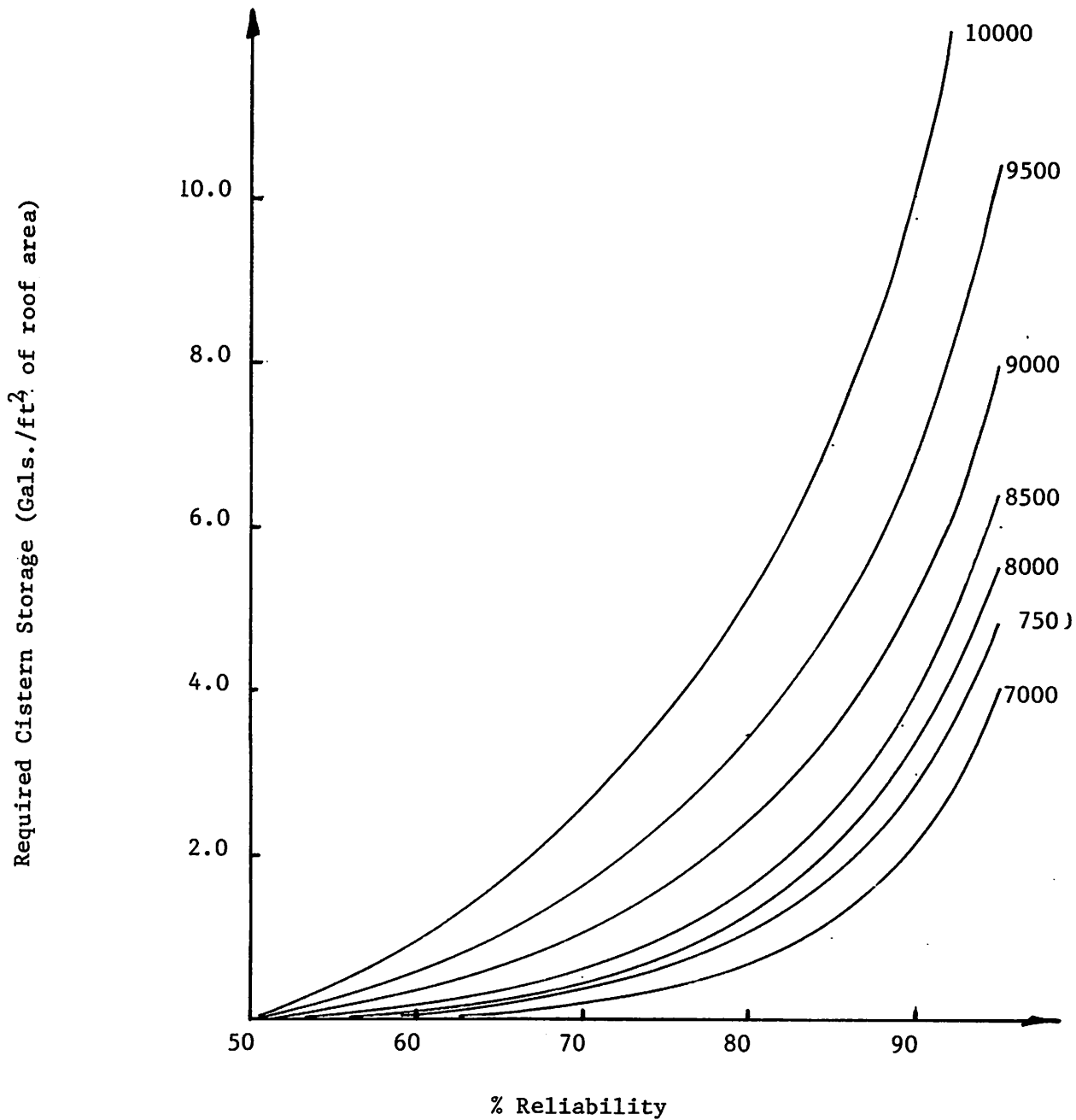
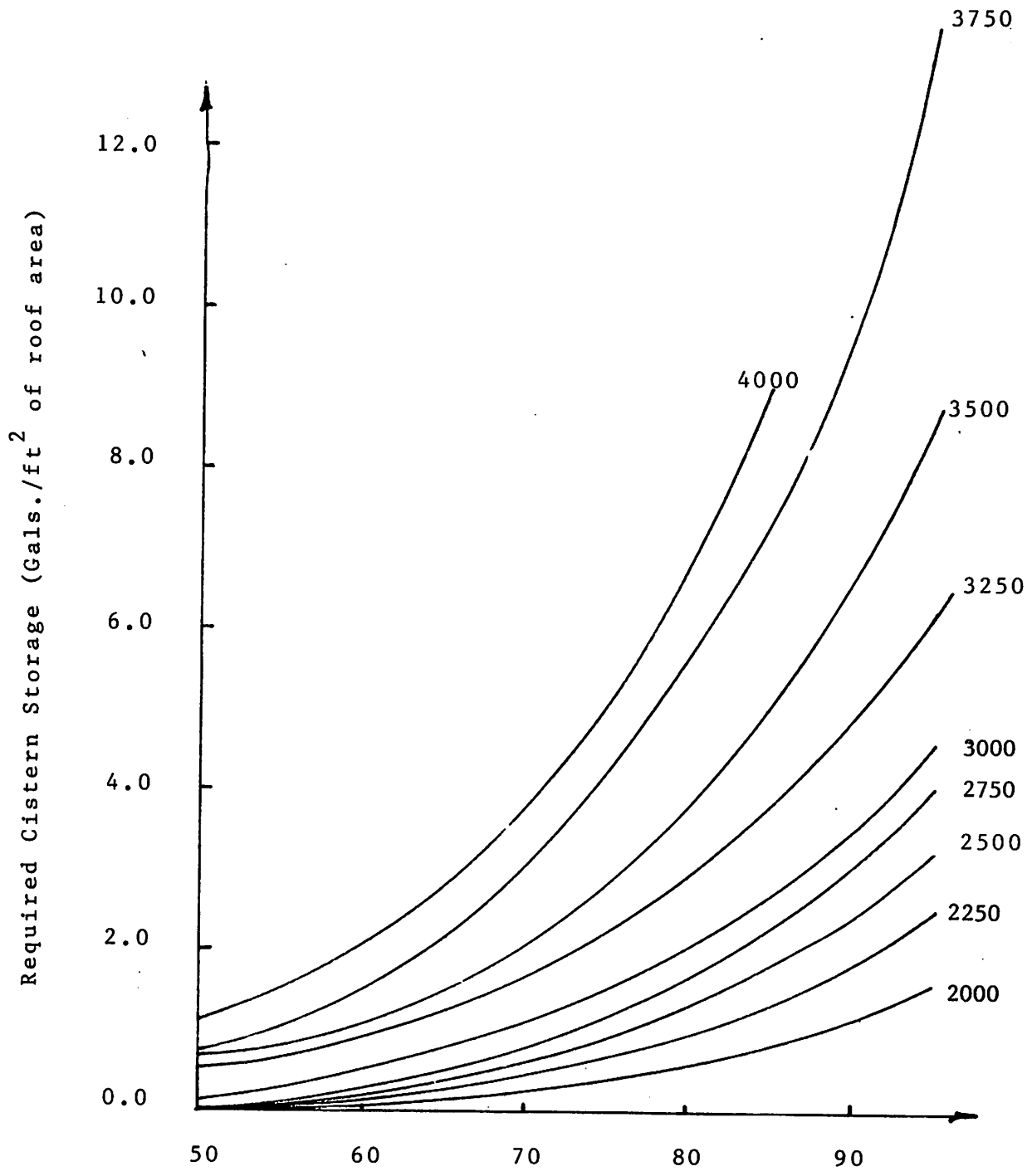

Figure 10

Design Curves for Koror, Belau with 85% Catchment Efficiency for Several Demands



% Reliability

Figure 11

Design Curves for Tortola, BVI with 85% Catchment Efficiency

CONCLUSIONS AND RECOMMENDATIONS

The models developed in this study are capable of determining the minimum cistern storage capacity that would be required to satisfy a specified demand at a desired reliability level. Required inputs are a rainfall sequence of a chosen length, the area of the catchment surface, and a coefficient relating to its efficiency in transmitting intercepted water.

These models may be used in several ways. Planners and decision makers can use these models in formulation of rules and regulations pertaining to cistern sizing. Alternatively, for cistern systems already in operation, these models can assist in determination of current storage levels. Such information is critical when conjunctive use strategies apply.

Further work on these models may include provision for changes in demand with changes in storage levels. Such a provision would eliminate the possible inaccuracies that may occur when an average demand is utilized. Additionally, it may be desirable to increase demand as time progresses in keeping with the assumption that the standard of living will improve with time as will water use.

REFERENCES

1. Reid, George W., "Lessons of History in the Design and Acceptance of Rain Water Cistern Systems," in Proceedings of the International Conference on Rain Water Cistern Systems, Honolulu, Hawaii, June 1982 (Ed. Faith N. Fujimura).
2. Wentworth, C.K., "Rainfall, Tanks, Catchment and Family Use of Water," Hawaii Water Authority, Honolulu, Hawaii, 1959.
3. Beswick, R.G.B., "Water Resources Situation Report - Cayman Islands," Mosquito Research and Control Unit, Barbados, B.W.I. 1980.
4. Rinehart, F., et. al., "Water quality of Cistern Water in St. Thomas, U.S.V.I.," Technical Report No. 15, Caribbean Research Institute, St. Thomas, September 1983.
5. King, Thomas, L. and P.B. Bedient, "Effect of Acid Rain on Cistern Water Quality," in Proceedings of the International Conference on Rain Water Cistern Systems, Honolulu, Hawaii, June 1982.
6. Lenon, H., L. Curry, A. Miller and D. Patulski, "Insecticide Residues in Water and Sediment from Cisterns in the U. S. and British Virgin Islands," in Pesticides Monitoring Journal, Volume 6, Number 3, pp 188-193, December, 1972.
7. Jenkins, D. and F. Pearson, "Feasibility of Rain Water Collection Systems in California," Contribution No. 173, California Water Resources Research Center, University of California, Berkeley, 1978.
8. Michaelides, Georghios and Robert J. Young, "Protection of Water Quality from Roof Catchments by Appropriate Design and Maintenance," in Proceedings of the Second International Conference on Rain Water Cistern Systems, St. Thomas, U. S. Virgin Islands, June, 1984 (Ed. Henry H. Smith).
9. See Supra, Note 7.
10. Young, Edward S. and William E. Sharpe, "Rainwater Cisterns Design, Construction and Water Treatment," The Pennsylvania State University, University Park, Pennsylvania (undated).
11. See Supra, Note 4.
12. Coffin, and Richardson, Inc., "Water Conservation Under Conditions of Extreme Scarcity: The U. S. Virgin Islands," Technical Completion Report for U. S. Department of the Interior, Office of Water Research and Technology, Boston Massachusetts, December, 1981.
13. Schiller, E. J. and B. Latham, "Computerized Methods in Optimizing Rainwater Catchment Systems," in Proceedings of the International Conference on Rain Water Cistern Systems, Honolulu, Hawaii, June, 1982 (Ed. Faith N. Fujimura).

APPENDIX A

DESIGN CURVES FOR SPRAT HOLE, ST. CROIX, USVI
WITH CATCHMENT EFFICIENCIES FROM 70% to 90%

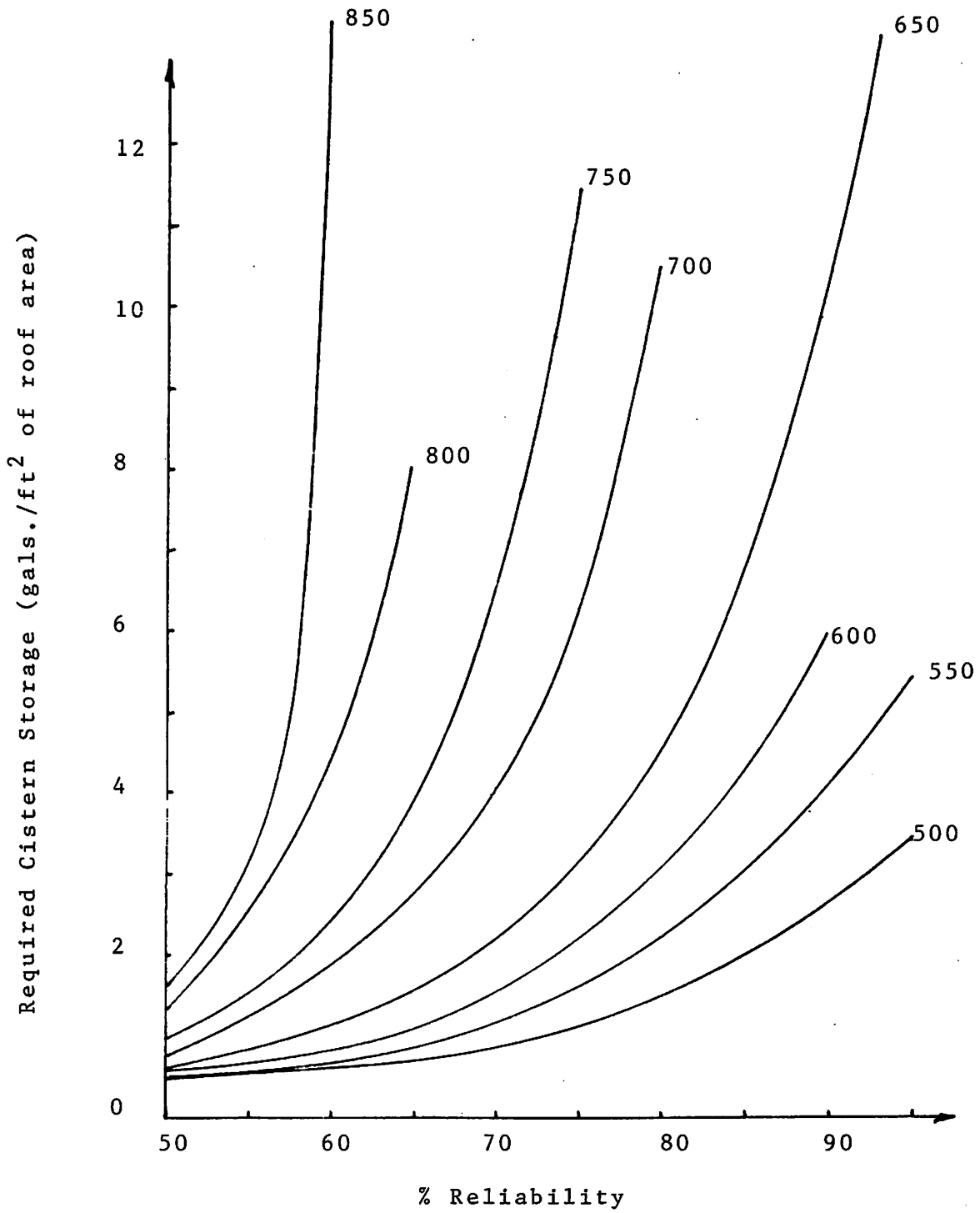

Figure A - 1

Design Curves for Sprat Hole, St. Croix for Several Demand Levels with Catchment Efficiency of 70%

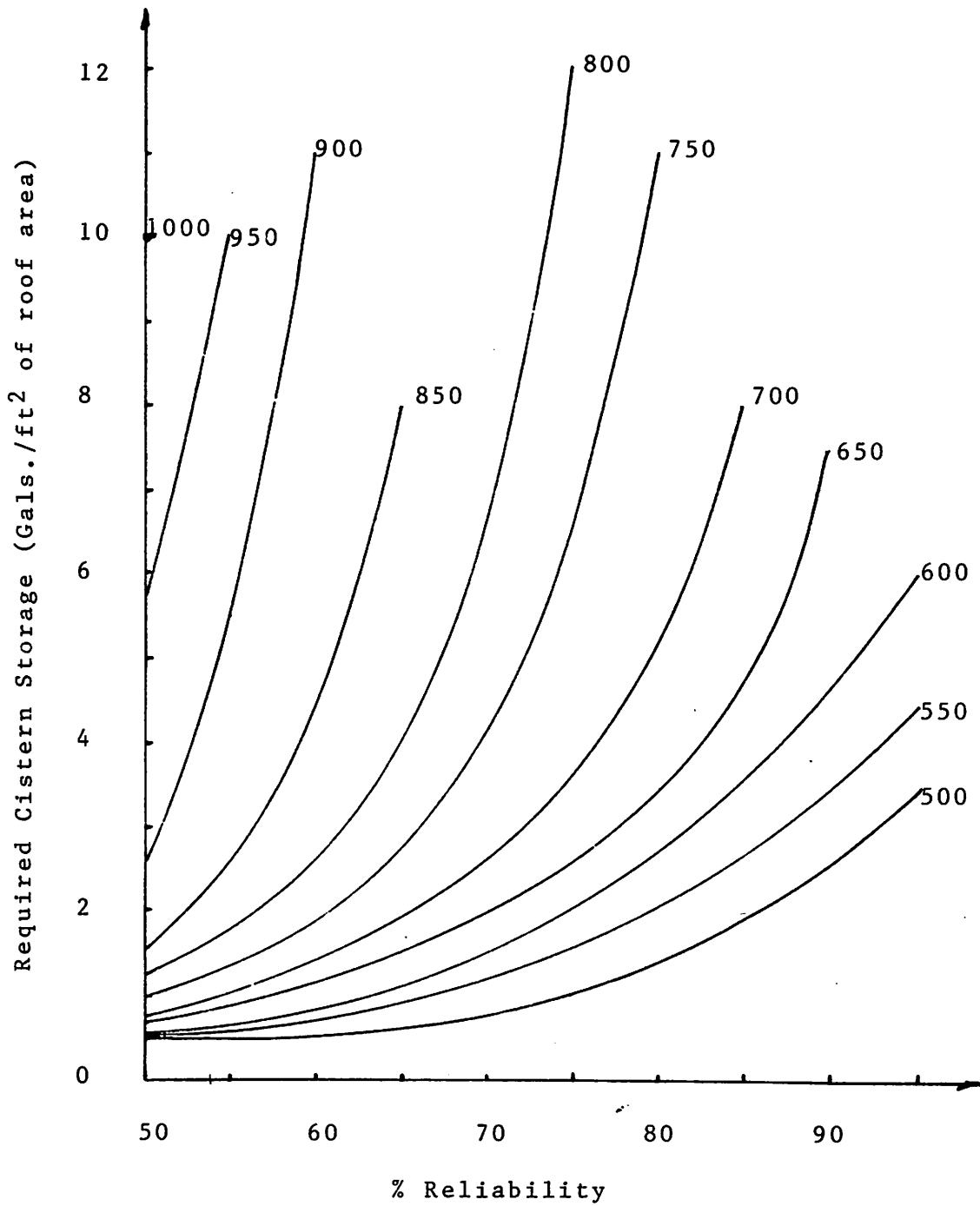

Figure A - 2

Design Curves for Sprat Hole, St. Croix for Several Demand Levels with Catchment Efficiency of 75%

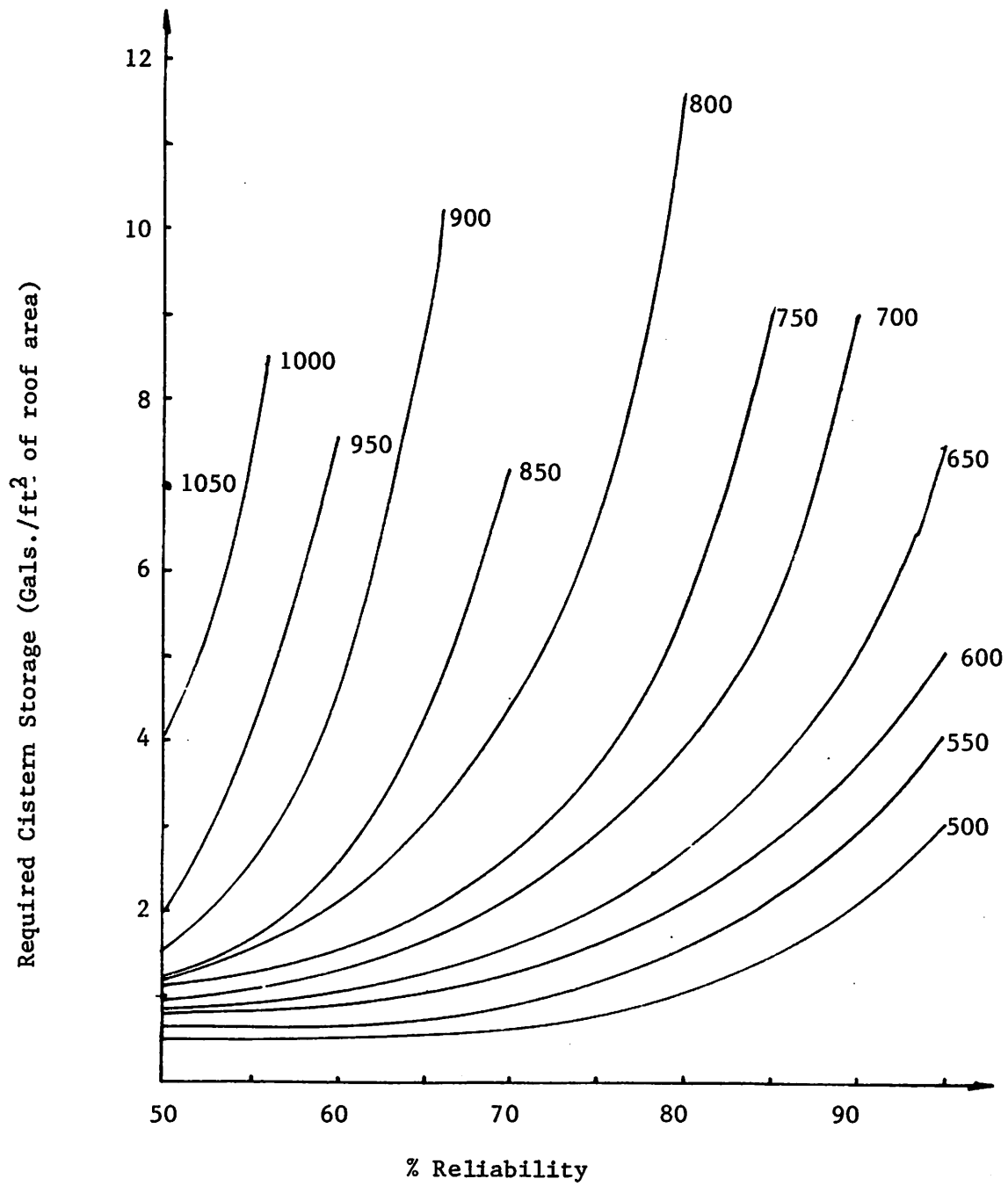

Figure A - 3

Design Curves for Sprat Hole, St. Croix for Several Demand Levels with Catchment Efficiency of 80%

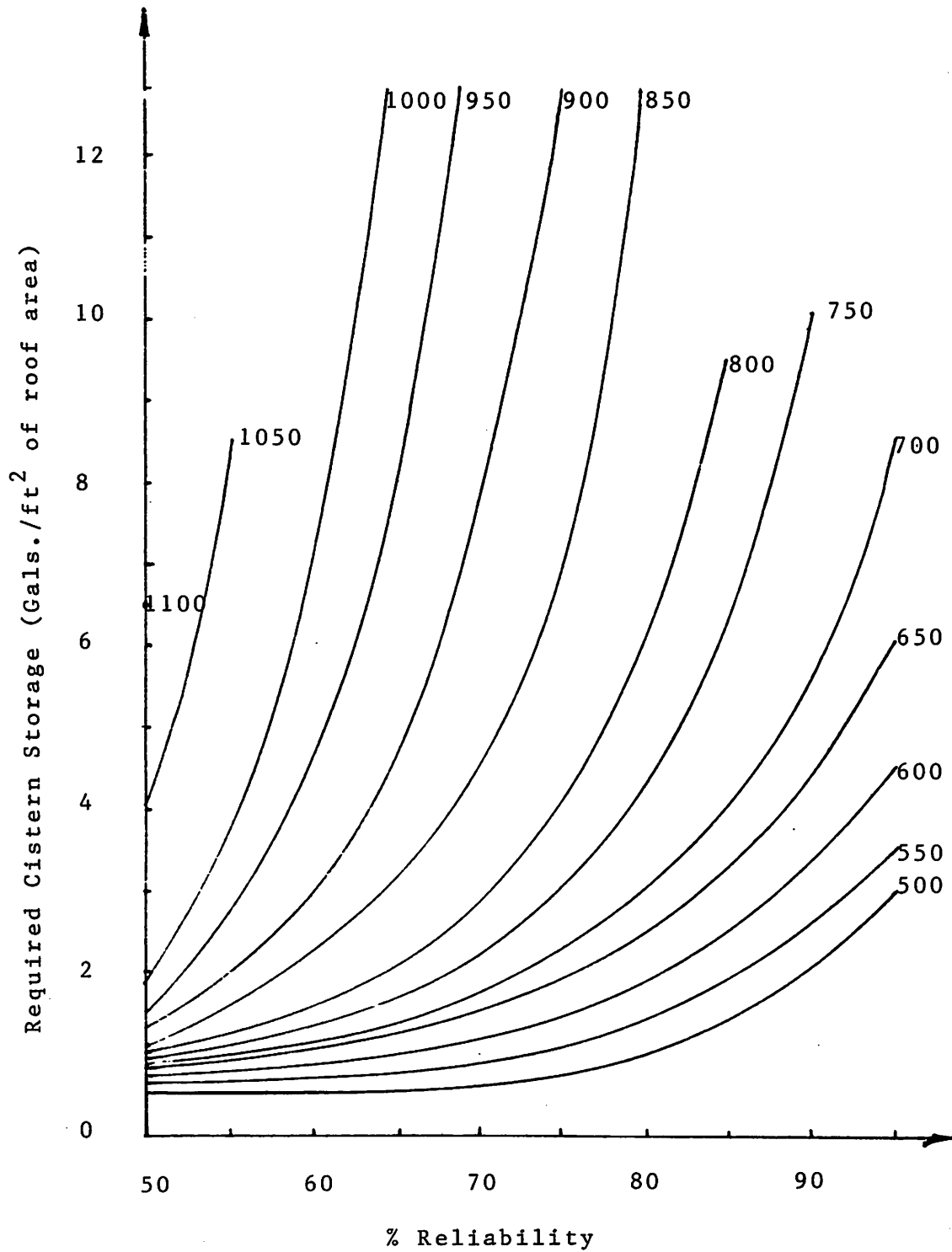

Figure A - 4

Design Curves for Sprat Hole, St. Croix for Several Demand Levels with Catchment Efficiency of 85%

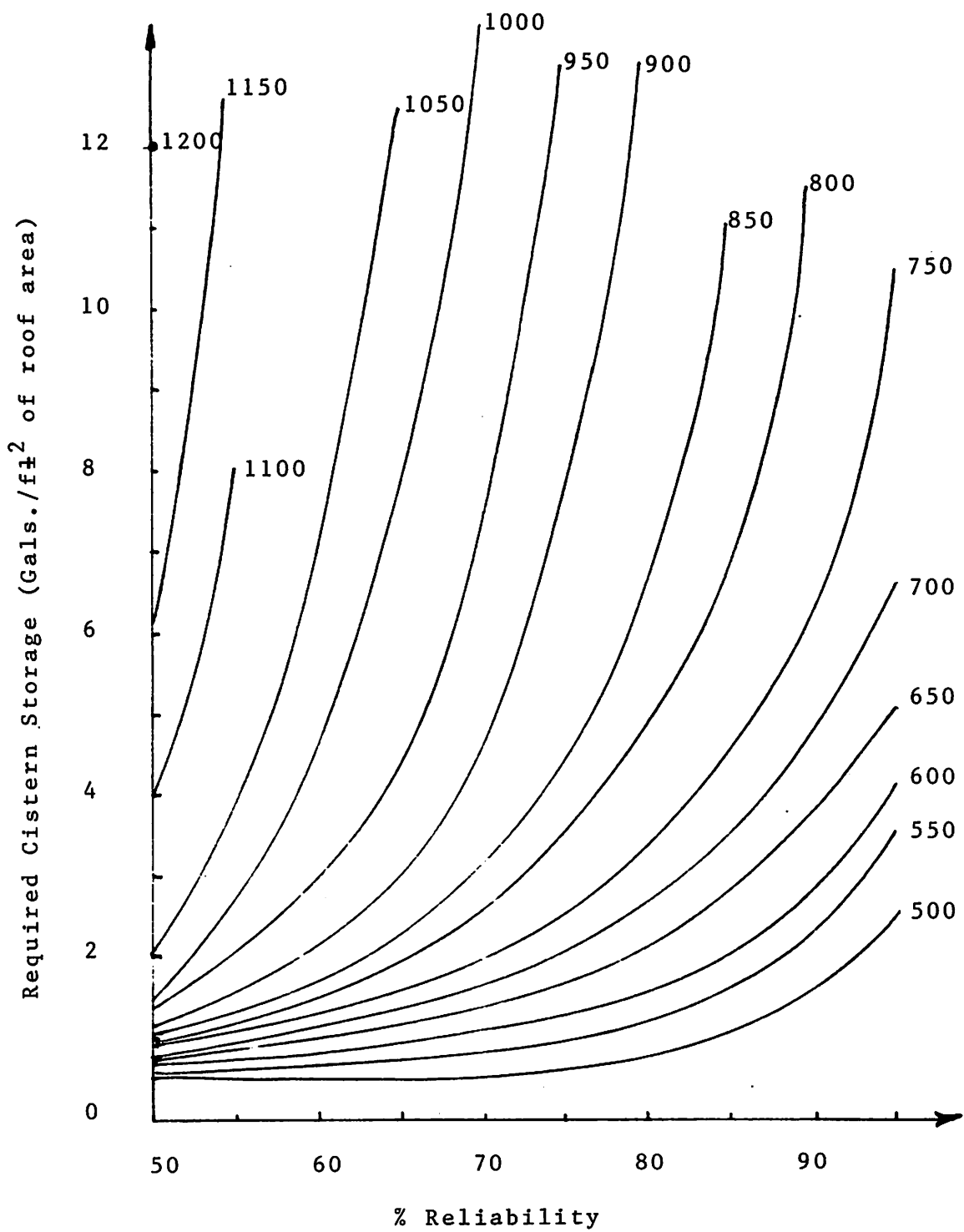

Figure A - 5

Design Curves for Sprat Hole, St. Croix for Several Demand Levels with Catchment Efficiency of 90%

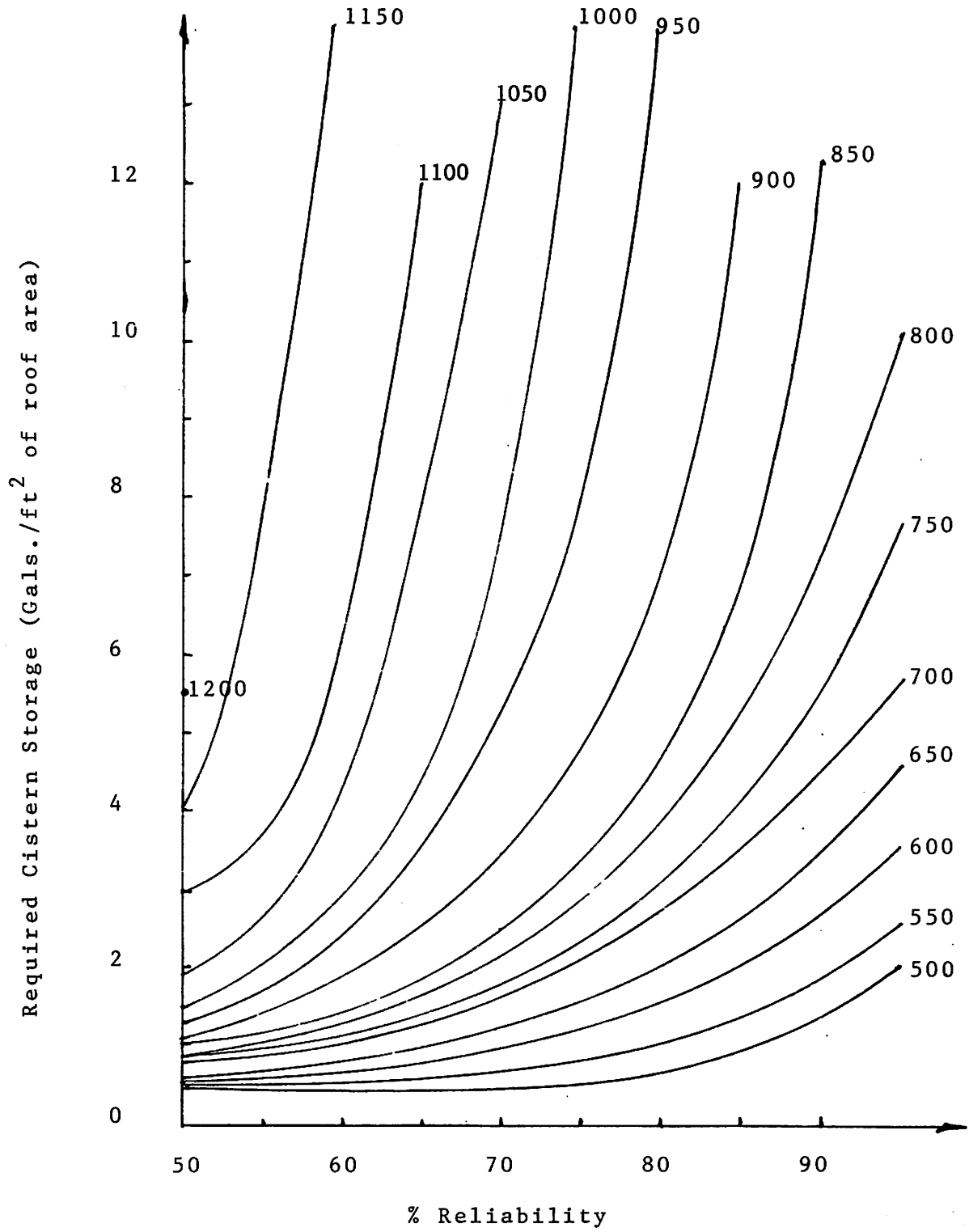

Figure A - 6

Design Curves for Sprat Hole, St. Croix for Several Demand Levels with Catchment Efficiency of 95%

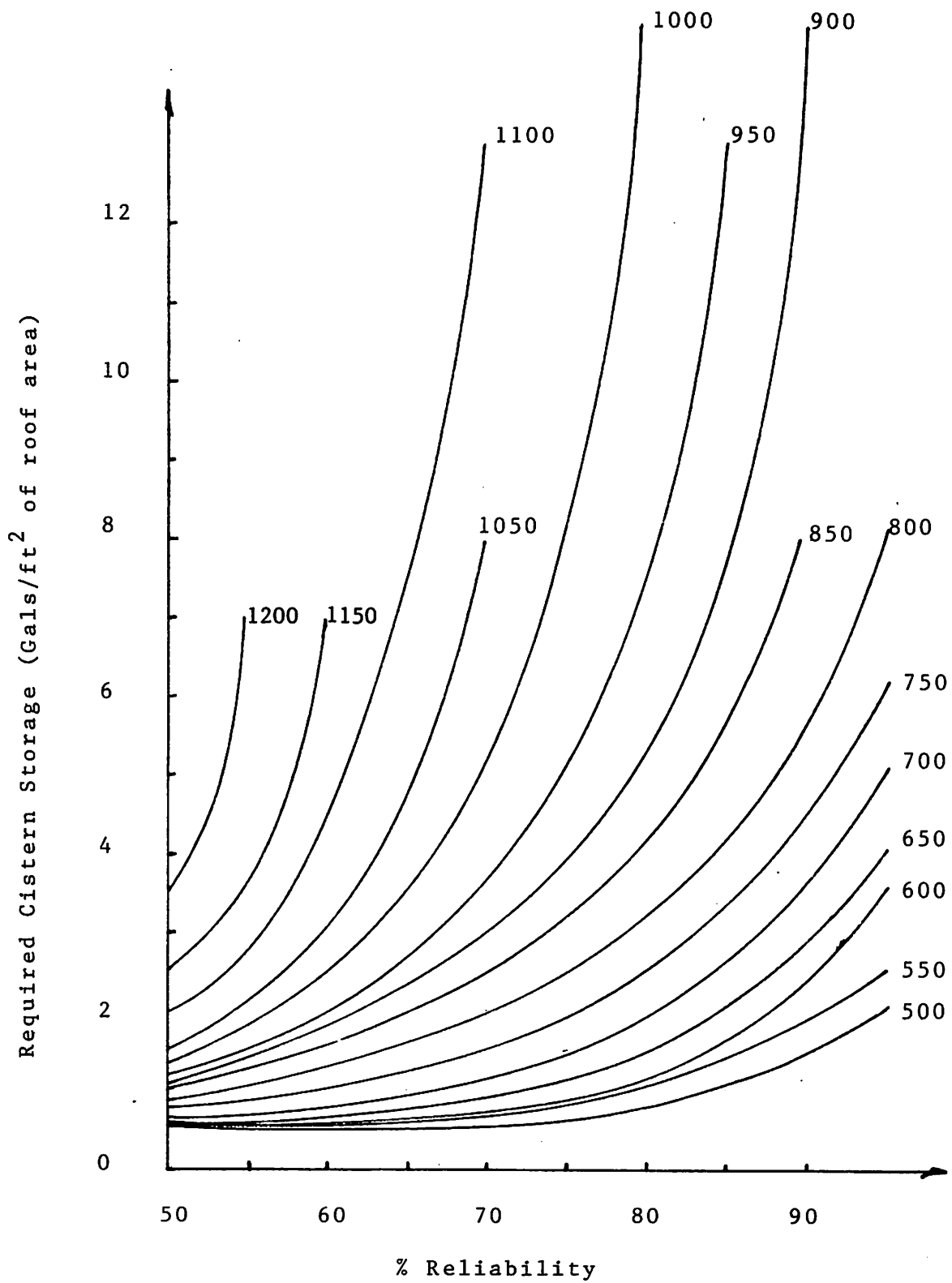

Figure A - 7

Design Curves For Sprat Hole St. Croix for Several Demand Levels with Catchment Efficiency of 100%

APPENDIX B

LISTINGS OF CISTERN RELIABILITY AND CISTERN DEMAND

LISTING OF CISTERN DEMAND

```

5  REM PROGRAM CISTERN DEMAND
10 REM DETERMINES REQUIRED STORAGE FOR SEVERAL DEMAND LEVELS
15 REM WITHIN SPECIFIED RELIABILITY RANGES
20 REM BY C. BROWNE AND H. SMITH - CARIBBEAN RESEARCH INSTITUTE
25 REM ST.THOMAS, VIRGIN ISLANDS
30 REM SUMMER, 1984
35 DIM L$(53),HL(2,53),ID$(25),D(25,53),HA(21,53),CS(21,52)
40 D$ = CHR$(4): REM CONTROL-D FILE
45 REM POSITION TO START OF FILE
50 PRINT D$;"OPEN STT WEEKLY"
55 PRINT D$;"READ STT WEEKLY"
60 INPUT NC
65 INPUT NV
70 INPUT MC
75 FOR A = 1 TO NV
80 INPUT L$(A)
85 INPUT HL(1,A)
90 INPUT HL(2,A)
95 NEXT A
100 INPUT Q$
105 REM CASES INFORMATION
110 FOR B = 1 TO NC
115 INPUT ID$(B)
120 FOR A = 1 TO NV
125 INPUT D(B,A):D(B,A) = D(B,A) / 12: IF D(B,A) < 0 THEN D(B,A) = 0
130 NEXT A: NEXT B
135 PRINT D$;"CLOSE STT WEEKLY": HOME
140 INPUT "NUMBER OF YEARS OF RECORDS? ";NY
145 PRINT "RUN FOR SEVERAL RELIABLITIES?"
150 GET SR$: IF SR$ = "" GOTO 150
155 IF SR$ = "Y" GOTO 675
160 DE = 0:COUNT = 0:CX = 99
165 HOME
170 INPUT "CATCHMENT EFFICIENCY? ";CE:CE = CE / 100
175 INPUT "CATCHMENT AREA? ";CA
180 INPUT "DESIRED RELIABILITY?";DR:LS = (100 - DR) / 100
185 INPUT "MINIMUM REQUIRED STORAGE?";RS:MX = RS
190 PRINT "FOR SEVERAL DEMANDS?"
195 GET A$: IF A$ = "" THEN 195
200 IF A$ = "Y" GOTO 475
205 INPUT "WEEKLY DEMAND IN GALLONS?";DM
210 COUNT = COUNT + 1:SPILL = 0
215 FOR Y = 1 TO NY: FOR WK = 1 TO 52:PW = WK - 1
220 SV = CA * RS
225 HA(Y,WK) = ((CA * D(Y,WK) * CE) * 7.48) - DM
230 IF Y = 1 AND PW = 0 THEN CS(Y,WK) = HA(Y,WK): GOTO 245
235 IF PW = 0 THEN CS(Y,WK) = CS((Y ->1),52): GOTO 245
240 CS(Y,WK) = CS(Y,PW) + HA(Y,WK)
245 IF CS(Y,WK) > SV THEN CS(Y,WK) = SV:SPILL = 1

```

```

250 IF CS(Y,WK) < 0 THEN CS(Y,WK) = 0:DE = DE + 1
255 IF (DE / (NY * 52)) > LS THEN GOTO 620
260 D(Y,WK) = INT (D(Y,WK) * 100 + .5) / 100
265 HA(Y,WK) = INT (HA(Y,WK) * 35 + .5) / 10
270 CS(Y,WK) = INT (CS(Y,WK) * 35 + .5) / 10
275 IF RS > 30 GOTO 615
280 NEXT WK: NEXT Y
285 PRINT "FOR A DEMAND OF "DM;
290 " REQUIRED STORAGE IS "RS" GALS./SQ.FT."
295 IF CX = 99 THEN LRS = RS
300 REM STORING MIN RS FOR NEXT RELIABILITY SATISFACTION
305 TPRS = RS: CX = 0: COUNT = 0: IF GG = 1 GOTO 535
310 PRINT "DO YOU WANT A LISTING ?"
315 GET X$: IF X$ = "" THEN 315
320 IF X$ = "N" THEN GOTO 340
325 FOR Y = 1 TO NY: FOR WK = 1 TO 52
330 PRINT "RAIN="D(Y,WK)" CATCH="HA(Y,WK)" STORED="CS(Y,WK)"
335 NEXT WK: NEXT Y
340 PRINT "DO YOU WANT A PRINTED OUTPUT? "
345 GET X$: IF X$ = "" THEN 345
350 IF X$ = "N" THEN GOTO 470
355 INPUT "STARTING WITH YEAR";BY
360 INPUT "ENDING WITH YEAR";EY
365 PR# 1: PRINT ""
370 FOR I = BY TO EY STEP 2
375 PRINT "" TAB( 3)"WEEK YEAR RAIN STORAGE";
380 PRINT "" TAB( 5)"YEAR RAIN STORAGE": PRINT ""
385 FOR WK = 1 TO 52: J = I + 1
390 PRINT "" TAB( 4)WK;
395 PRINT "" TAB( 7 - LEN ( STR$ (WK)))I;
400 PRINT "" TAB( 9 - LEN ( STR$ (I)))D(I,WK);
405 PRINT "" TAB( 9 - LEN ( STR$ (D(I,WK))))CS(I,WK);
410 PRINT "" TAB( 14 - LEN ( STR$ (CS(I,WK))))J;
415 PRINT "" TAB( 5 - LEN ( STR$ (J)))D(J,WK);
420 PRINT "" TAB( 9 - LEN ( STR$ (D(J,WK))))CS(J,WK)
425 NEXT WK: PRINT "": PRINT ""
430 IF I < (EY - 1) GOTO 460
435 PRINT "FOR A RELIABILITY OF "DR"% REQUIRED STORAGE IS "RS;
440 PRINT "GALS./SQ.FT."
445 PRINT NY"YEARS",WEEKLYDEM AND OF"DM"AREAOF"CA;
450 PRINT "SQ.FT. AND EFFICIENCYOF"CE
455 GOTO 465
460 FOR C = 1 TO 5: PRINT CHR$ (10): NEXT C: NEXT I
465 PR# 0
470 GOTO 585
475 REM SETTING UP FOR SEVERAL INCREMENTS
480 GG = 1: PRS = RS
485 INPUT "MINIMUM DEMAND?";MM
490 DM = MM

```

```

500 PRINT "DO YOU WANT A PRINTED OUTPUT? "
505 GET X$: IF X$ = "" THEN 505
510 IF X$ = "N" GOTO 530
515 PR# 1: PRINT "": PRINT "RELIABILITY IS "DR;
520 PRINT "CATCHMENT IS "CA" SIMULATION FOR "NY" YEARS"
525 PRINT "CATCHMENT EFFICIENCY IS "CE: PRINT ""
530 GOTO 210
535 REM
540 DM = DM + 50: IF DM > MD THEN GOTO 585
545 GOSUB 650
550 DE = 0: GOTO 210
555 GOTO 210
560 IF X$ = "N" GOTO 585
565 PRINT "A HIGHER DEMAND SATISFACTION IS UNLIKELY": GOTO 585
570 REM
575 REM
580 REM
585 IF SR$ = "Y" GOTO 690
590 PRINT "RERUN THE PROGRAM?"
595 GET R$: IF R$ = "" THEN 595
600 IF R$ = "N" GOTO 615
605 DE = 0: COUNT = 0: CX = 99
610 GOTO 165
615 END
620 REM
625 PRINT "SPILL="SPILL: IF SPILL = 0 GOTO 565
630 IF CX = 99 THEN COUNT = 0: GOTO 640
635 IF COUNT > 10 GOTO 565
640 PRINT "Y="Y"WK="WK"DE="DE"RS="RS"SPILL="SPILL
645 DE = 0: RS = RS + 0.5: GOTO 210
650 REM INCREMENTING 'RS' BASED ON PAST TRENDS
655 DI = RS - PRS: IF DI > 0.5 GOTO 665
660 PRS = TPRS: GOTO 670
665 RS = RS + (RS - PRS): PRS = TPRS
670 RETURN
675 INPUT "MINIMUM REQUIRED RELIABILITY"; DR
680 INPUT "MAXIMUM REQUIRED RELIABILITY"; MAXR
685 GOTO 160
690 IF DR > = MAXR GOTO 615
695 DR = DR + 5: LS = (100 - DR) / 100
700 DM = MM: REM RESETTING DEMAND
705 RS = LRS: REM RESETTING TO LEAST FEASIBLE REQUIRED STORAGE
710 DE = 0: COUNT = 0: CX = 99
715 PRINT : PRINT "RELIABILITY IS NOW "DR: PRINT
720 IF GG = 0 GOTO 735
725 REM
730 REM
735 GOTO 210

```

LISTING OF CISTERN RELIABILITY

```

5  REM  PROGRAM CISTERN RELIABILITY
10  REM  DETERMINES REQUIRED STORAGE FOR SEVERAL RELIABILITY
15  REM  LEVELS WITHIN SPECIFIED DEMAND RANGES.
20  REM  BY C. BROWNE AND H. SMITH - CARIBBEAN RESEARCH INSTITUTE
25  REM  ST. THOMAS,VIRGIN ISLANDS
30  REM  SUMMER, 1984
35  DIM L$(53),HL(2,53),ID$(25),D(25,53),HA(21,53),CS(21,52)
40  D$ = CHR$(4): REM CONTROL-D FILE
45  REM POSITION TO START OF FILE
50  PRINT D$;"OPEN STT WEEKLY"
55  PRINT D$;"READ STT WEEKLY"
60  INPUT NC
65  INPUT MC
70  FOR A = 1 TO NV
75  INPUT L$(A)
80  INPUT HL(1,A)
85  INPUT HL(2,A)
90  NEXT A
95  INPUT Q$
100 REM CASES INFORMATION
105 FOR B = 1 TO NC
110 INPUT ID$(B)
115 FOR A = 1 TO NV
120 INPUT D(B,A):D(B,A) = D(B,A) / 12
125 IF D(B,A) < 0 THEN D(B,A) = 0
130 NEXT A: NEXT B
135 PRINT D$;"CLOSE STT WEEKLY": HOME
140 INPUT "NUMBER OF YEARS OF RECORDS? ";NY
145 PRINT "RUN FOR SEVERAL DEMANDS?"
150 GET SR$: IF SR$ = "" GOTO 150
155 IF SR$ = "Y" GOTO 675
160 DE = 0:COUNT = 0:CX = 99
165 HOME
170 INPUT "CATCHMENT EFFICIENCY? ";CE:CE = CE / 100
175 INPUT "CATCHMENT AREA?";CA
180 INPUT "WEEKLY USAGE RATE?";DM
185 INPUT "MINIMUM REQUIRED STORAGE?";RS:MX = RS
190 PRINT "FOR SEVERAL RELIABILITIES ?"
195 GET A$: IF A$ = "" THEN 195
200 IF A$ = "Y" GOTO 475
205 INPUT "DESIRED RELIABILITY? ";DR:LS = (100 - DR) / 100
210 COUNT = COUNT + 1:SPILL = 0
215 FOR Y = 1 TO NY: FOR WK = 1 TO 52:PW = WK - 1
220 SV = CA * RS
225 HA(Y,WK) = ((CA * D(Y,WK) * CE) * 7.48) - DM
230 IF Y = 1 AND PW = 0 THEN CS(Y,WK) = HA(Y,WK): GOTO 245
235 IF PW = 0 THEN CS(Y,WK) = CS((Y - 1),52): GOTO 245
240 CS(Y,WK) = CS(Y,PW) + HA(Y,WK)
245 IF CS(Y,WK) > SV THEN CS(Y,WK) = SV:SPILL = 1

```

```

250 IF CS(Y,WK) < 0 THEN CS(Y,WK) = 0:DE = DE + 1
255 IF (DE / (NY * 52)) > LS THEN GOTO 620
260 D(Y,WK) = INT (D(Y,WK) * 70 + .5) / 100
265 HA(Y,WK) = INT (HA(Y,WK) * 5 + 0.5) / 10
270 CS(Y,WK) = INT (CS(Y,WK) * 5 + .5) / 10
275 IF RS > 30 GOTO 615
280 NEXT WK: NEXT Y: IF DE < 4 GOTO 585
285 PRINT "FOR A RELIABILITY OF"DR;
290 PRINT "% REQUIRED STORAGE IS "RS" GALS./SQ.FT."
295 IF CX = 99 THEN LRS = RS
300 REM ABOVE STORES MIN RS FOR NEXT DEMAND SATISFACTION
305 TPRS = RS: CX = 0: COUNT = 0: IF GG = 1 GOTO 535
310 PRINT "DO YOU WANT A LISTING ?"
315 GET X$: IF X$ = "" THEN 315
320 IF X$ = "N" THEN GOTO 340
325 FOR Y = 1 TO NY: FOR WK = 1 TO 52
330 PRINT "RAIN="D(Y,WK)" CATCH="HA(Y,WK)" STORED="CS(Y,WK)"
335 NEXT WK: NEXT Y
340 PRINT "DO YOU WANT A PRINTED OUTPUT? "
345 GET X$: IF X$ = "" THEN 345
350 IF X$ = "N" THEN GOTO 470
355 INPUT "STARTING WITH YEAR";BY
360 INPUT "ENDING WITH YEAR?";EY
365 PR# 1: PRINT ""
370 FOR I = BY TO EY STEP 2
375 PRINT "" TAB( 3)"WEEK YEAR RAIN STORAGE";
380 PRINT "" TAB( 5)"YEAR RAIN STORAGE": PRINT ""
385 FOR WK = 1 TO 52: J = I + 1
390 PRINT "" TAB( 4)WK;
395 PRINT "" TAB( 7 - LEN ( STR$ (WK)))I;
400 PRINT "" TAB( 9 - LEN ( STR$ (I)))D(I,WK);
405 PRINT "" TAB( 9 - LEN ( STR$ (D(I,WK))))CS(I,WK);
410 PRINT "" TAB( 14 - LEN ( STR$ (CS(I,WK))))J;
415 PRINT "" TAB( 5 - LEN ( STR$ (J)))D(J,WK);
420 PRINT "" TAB( 9 - LEN ( STR$ (D(J,WK))))CS(J,WK)
425 NEXT WK: PRINT "": PRINT ""
430 IF I < (EY - 1) GOTO 460
435 PRINT "FOR A RELIABILITY OF "DR"% REQUIRED STORAGE IS "RS;
440 PRINT " GALS./SQ.FT."
445 PRINT NY"YEARS",WEEKLYDEM AND OF"DM"AREAOF"CA;
450 PRINT "SQ.FT. AND EFFICIENCYOF"CE
455 GOTO 465
460 FOR C = 1 TO 5: PRINT CHR$ (10): NEXT C: NEXT I
465 PR# 0
470 GOTO 585
475 REM SETTING UP FOR SEVERAL INCREMENTS
480 GG = 1: PRS = RS
485 INPUT "MINIMUM REQUIRED RELIABILITY?";RR
490 DR = RR: LS = (100 - DR) / 100

```

```

500 PRINT "DO YOU WANT A PRINTED OUTPUT? "
505 GET X$: IF X$ = "" THEN 505
510 IF X$ = "N" GOTO 530
515 PR# 1: PRINT "": PRINT "DEMAND IS "DM" CATCHMENT IS "CA;
520 PRINT " SIMULATION FOR "NY" YEARS"
525 PRINT "CATCHMENT EFFICIENCY IS"CE: PRINT ""
530 GOTO 210
535 REM
540 DR = DR + 5: IF DR > MR GOTO 585
545 GOSUB 650
550 LS = (100 - DR) / 100:DE = 0: GOTO 210
555 GOTO 210
560 IF X$ = "N" GOTO 585
565 PRINT "A HIGHER RELIABILITY IS UNLIKELY": GOTO 585
570 REM
575 REM
580 REM
585 IF SR$ = "Y" GOTO 690
590 PRINT "RERUN THE PROGRAM?"
595 GET R$: IF R$ = "" THEN 595
600 IF R$ = "N" GOTO 615
605 DE = 0:COUNT = 0:CX = 99
610 GOTO 165
615 END
620 REM
625 PRINT "SPILL="SPILL: IF SPILL = 0 GOTO 565
630 IF CX = 99 THEN COUNT = 0: GOTO 640
635 IF COUNT > 10 GOTO 565
640 PRINT "Y="Y"WK="WK"DE="DE"RS="RS"SPILL="SPILL
645 DE = 0:RS = RS + 0.5: GOTO 210
650 REM INCREMENTING 'RS' BASED ON PAST TRENDS
655 DI = RS - PRS: IF DI > 0.5 GOTO 665
660 PRS = TPRS: GOTO 670
665 RS = RS + (RS - PRS):PRS = TPRS
670 RETURN
675 INPUT "MINIMUM REQUIRED DEMAND";DM
680 INPUT "MAXIMUM REQUIRED DEMAND";MAXD
685 GOTO 160
690 IF DM > = MAXD GOTO 615
695 DM = DM + 50
700 DR = RR:LS = (100 - DR) / 100: REM RESETTING RELIABILITY
705 RS = LRS: REM RESETTING TO LEAST FEASIBLE REQUIRED STORAGE
710 DE = 0:COUNT = 0:CX = 99
715 PRINT : PRINT "DEMAND IS NOW"DM: PRINT
720 IF GG = 0 GOTO 735
725 REM
730 REM
735 GOTO 210

```